

BROADCAST NEWS



Vol. No. 125
FEB. 1965

RCA "NEW LOOK" TV TAPE PLAYER



TV Film Projector

A deluxe model
with every feature
your program people
could ask for

This new equipment does what you would expect from the world's most advanced television film projector. It has deluxe features, like instant start, reversible operation and automatic cue. These assure the finest quality and versatility. Completely transistorized and automated, the TP-66 is specially designed for TV film programming's faster pace.

INSTANTANEOUS START—Start and show buttons can be pushed at the same time, since projector sound is stabilized within 0.3 second. A pre-roll period, prior to switching projector "on air," is not necessary. Start is instantaneous, allowing preview of upcoming film when desired.

STILL-FRAME PROJECTION—Single frames can be shown at full light level for extended periods, permitting preview of first frame at start, or for special effects. Film is always completely protected by a filter that automatically moves into light path during still-frame use.

FILM REVERSING—Film motion can be reversed—a time-saving feature when rehearsing live or tape shows with film inserts... or as an imaginative production device.

AUTOMATIC CUEING—For full or partial automation, films can be stopped and cued up automatically. This eliminates the need for manually threading and cueing individual films, eliminating human error.

AUTOMATIC LAMP CHANGE—Both projection and exciter lamps are automatically switched in place, when burnout occurs. These time-saving features assure continuous operation and avoid costly delays.

AUTOMATIC LOOP RESTORER—Unique fail-proof feature eliminates need for human intervention, makes unattended operation practical.

TRANSISTORIZED SOUND—The TP-66 can be equipped for both magnetic and optical sound systems. Fully transistorized for finest quality and reliability.

NOW BEING DELIVERED

For full particulars, write RCA Broadcast and Television Equipment, Building 15-5, Camden, N.J. Or see your RCA Broadcast Representative.



New 16mm Television Film Projector, Type TP-66



The Most Trusted Name
in Television

BROADCAST NEWS

published by

RADIO CORPORATION OF AMERICA

BROADCAST & COMMUNICATIONS PRODUCTS DIVISION, CAMDEN, N. J.

issued bi-monthly

PRICE *in U.S.A. - - - - - \$6.00 for 6 issues*
outside U.S.A. - - - \$7.00 for 6 issues

CONTENTS

	Page
New TV Tape Player	12
WBRE Installs Silicon Rectifiers to Update TV Transmitter	18
New RCA Color Film Camera	20
Selecting A UHF Antenna	30
Multi-Cartridge Audio Tape Playback System	38

THE VICE PRESIDENT AND THE JANITOR both learned within a few hours how to operate the TR-3 Tape Player we recently installed for a customer. And it's hard to say who gets the most pleasure out of running it. Which reminds us of our earlier prediction that the TR-3 would be one of our most popular products. How can it miss? When a station manager comes to the big town with a tape under his arm, he wants to be able to show it to his rep—and probably to agency buyers. We think every rep will have to have one. So will big agencies. Some of the latter have bought slant-track machines—which are all right for playing producer—but don't help any in showing quadruplex tapes. They need a TR-3—or a TR-4 if they want to record, too. So far we haven't pushed this market because we've been so busy delivering TR-3's to station cus-

*As We Were
Saying*

Continued on following page

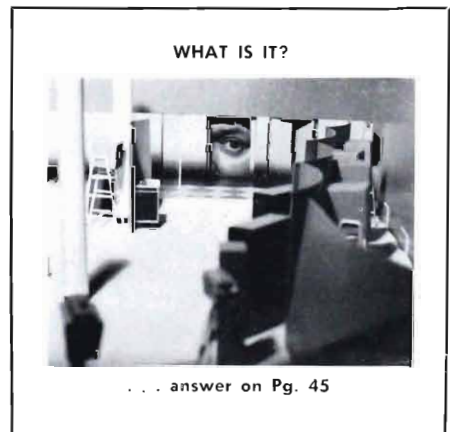

RIGHT—RCA TR-3 Tape Players such as the one shown here, and on the cover of this issue are being shipped to stations, agencies and reps. More than 75 have already been shipped.



BELOW—RCA TK-27 Color Film Cameras are nearly ready with more than 70 scheduled for shipment in the next few months.



tomers. However, as we approach the point where we can make quick deliveries on new orders, we will be out there trying to persuade these folks to install TR-3's. We think it will serve the interests of our station customers to do so.

The story on Page 15 tells what one of the most progressive reps is doing with a TR-3 Player. In this case not only doing something they couldn't do before—but saving money, too.

THEY WAITED, and are they glad! Meaning our friends and good customers who are now receiving the TK-27 (4-V) Color Film Cameras they ordered way back when.

It's a long story—with a happy ending! Like most such things the "4-V" idea dates way back. It was fully described by Dr. A. N. Goldsmith (then Chief Engineer of RCA) in a patent filed Oct. 12, 1944. However, for practical purposes our story begins some years ago. At that time our television development group under Dr. Kozanowski started in earnest to develop practical 4-V cameras. At the 1962 NAB Convention we showed one of his live "4-V" Cameras and asked broadcasters for their reactions (oh boy, did we get them!) At the 1963 NAB we showed the first 4-V Film Camera to be exhibited anywhere. It worked beautifully—but it was not yet ready for

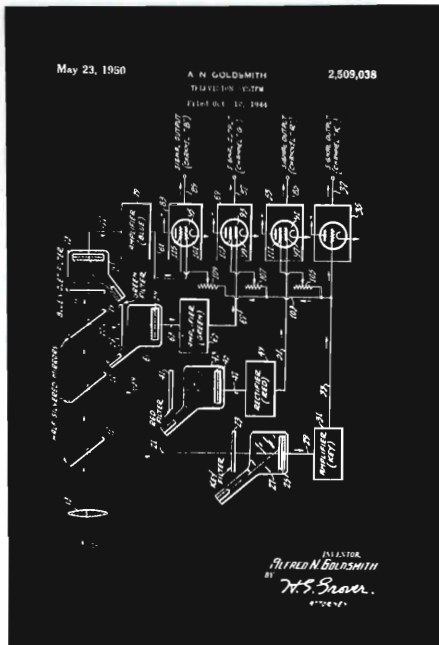

"4-TUBE" PATENT filed October 12, 1944, by Dr. A. N. Goldsmith, RCA Chief Engineer. Four Iconoscopes would have made quite a camera. Idea became practical with the development of vidicons.

As We Were Saying

production. We asked broadcasters for their suggestions—and went back to the lab to incorporate them. Finally at the 1964 NAB we showed a prototype production model of our TK-27 (4-V) Film Camera. But horror of horrors, others did, too. And worse yet, started delivering before we could. It was painful to us, and embarrassing to our customers. But most of them stayed with us. Now they are receiving their TK-27's—and they're glad. For this is no rushed-into-production unit that simply adds a fourth channel to what we had. Rather, it is a carefully worked-out equipment which incorporates all the new improvements we could possibly get. For example, the 1½-inch vidicon in the luminance channel for a 50 per cent larger image; the all-new types of electro-static vidicons which make possible **all transistor** operation; the plug-in modules, most of them interchangeable with those in our other new cameras; the plug-in vidicon assemblies, replaceable without optical realignment; the prism optics with sealed dichroics. And many more you can read about in the article on Page 20.

HISTORY REPEATS, they say, and who's to argue—and this time almost 10 years to the day. When the lid came off of color in 1953 we had our first traumatic experience with color film equipment and it somewhat parallels what we've just



FIRST 3-V CAMERA SHOWING was at 1955 NAB Convention in Washington. In this photo Dr. Kozanowski who headed the team which developed the 3-V Camera is shown at the camera control position. This camera, the RCA Type TK-26 has been the standard color film camera for the past ten years.

gone through. At that time considerable work had been done on live camera development but very little on film cameras. The only immediate way to televise color film was by using the flying spot scanner technique. Several manufacturers rushed such equipment onto the market. We were even guilty of building a few ourselves. But it wasn't very satisfactory—and meantime, Dr. Kozanowski and his boys were working quietly in the back lab to develop something better. In **BROADCAST NEWS**, No. 79, for May-June 1954, he described it—a 3-V Color Film Camera. At the 1955 NAB Convention in Washington we showed for the first time the production model—our TK-26 (3-V) Color Film Camera. It swept the boards—and for the next ten years the RCA TK-26's (with the A's, B's, and C's, which incorporated minor improvements) were never even seriously challenged.

Now comes the RCA TK-27—under almost similar circumstances. The pace of development has accelerated, so that we don't really expect that the TK-27 will have the ten-year supremacy of the TK-26. But we do believe that it is a very worthy successor—and that for some years to come it will occupy the same outstanding position that the TK-26 did for so long. Don't say we didn't tell you.



EXPERIMENTAL MODEL (1962). First 4-tube Color Camera to be shown anywhere was this experimental model of the RCA TK-42 which was exhibited at the 1962 NAB. Broadcasters comments were solicited and were incorporated in following models.



LABORATORY MODEL (1964): This "almost ready" model of the TK-42 was shown at the 1964 NAB Convention.

THEY'RE WAITING—many of our same customers for our new TK-42 (4-V) Live Color Camera. This, too, is a camera we have had in development for some years—and of which we have shown interim models at earlier NAB Conventions. But in this case the situation is a little different. So far no one has offered a color camera in this class—and we don't expect they will very soon.

At last year's NAB we showed an almost ready model of the TK-42. We listened to comments—sent it back to labs for more rework—especially size reduction. But now (oh happy day) we are rolling. At the NAB Convention you will see the final model. Smaller, better, easier to operate than any color camera you've seen before.

In June we will start delivering TK-42's to the customers who have ordered them. That so many have ordered, without having seen a final model, and without knowing the final price, is an expression of confidence which we appreciate and value. We'll live up to it! The TK-42, like the TK-27, is the follower of illustrious predecessors—in this case the RCA TK-40 and TK-41 Live Color Cameras which for 12 years have been synonymous with Color TV. We think the TK-42 will be used wherever top quality in color is the first consideration.

COINCIDENCE can be interesting. Color, after ten years of stumbling progress, shows signs of com-

ing on big. And at this very right moment we just happen to have all-new color cameras ready for you. Also, most TV stations are around ten years old—well written-off and about ready for a complete redo. And, for this we just happen to have a truly revolutionary line of "new look" equipment at the ready. It would be nice to say we planned it that way—and in a sense we did. But any planner can tell you it doesn't often come out that well. So we're real happy. And you should be, too. For now you can make your new station really all new—all blue.

RAYMOND A. HEISING, according to a paragraph in TV DIGEST, died January 16, at the age of 76. The paragraph noted that he held 117 patents, went on to list his offices and honors. A very proper paragraph—probably culled from an obit by an editor who never heard of him, but was impressed by the statistics. For those of us who in the twenties were weaned on Morecroft, it hardly seems enough. In Lesson 2 of our indoctrination in broadcast engineering we learned about "constant current" modulation—and Prof. Morecroft said it was "apparently due to Heising." To today's young sophisticates it may seem simple—but to us it was magic. And indeed "Heising" modulation was used in every transmitter built during broadcasting's first 15 years. DeForest may have been the father of the audion but it was Heising who taught it to sing. For us Heising will always be synonymous with modulation.

*As We Were
Saying*

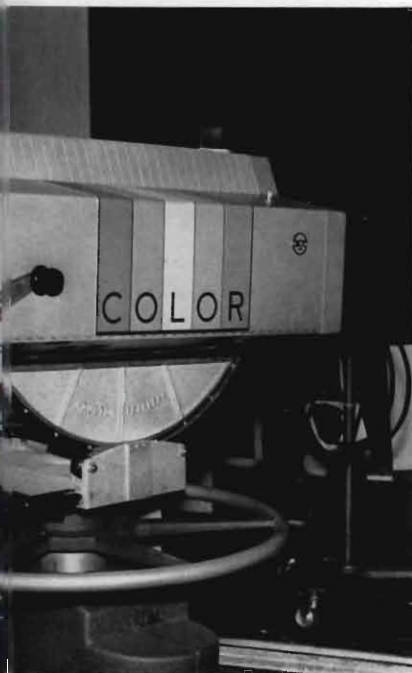

PRODUCTION MODEL (1965): This final prototype model of the TK-42 will be exhibited at this year's NAB. Already well along in production these cameras will start going out to customers within a few months.

As We Were Saying

WRITING FASCINATES us. We perpetrate this column in something the literates would call semi-English. Our excuse is the plebian need to "communicate." But mistake not, if we could write like the masters of the language, we would do so. In our generation one of the greatest of these was T. S. Eliot. Since his death some months ago all of the literary journals have extolled his works and his influence. Even such mundane magazines as LIFE have noted his passing and observed that he showed a generation the possibilities of the language. And so, perhaps, may we be forgiven for a note on Eliot—even though it certainly does not fall within our ordinary purview.

Like most of our reader-engineers we were, in our younger days, hell-bent to get an engineering education. And so, when we went to college, we took as few non-engineering courses as possible. We spent our time on statics, and kinetics, and drafting (ugh)—when we might have been sitting at the feet of the masters. One of them would have been Eliot. It is to regret—everlastingly.

And it leads one to question those who urge that more of our undergraduates take engineering. That we should send more of our young men to collage—no question. But that a higher percentage of them should take engineering—we wonder. Should we send men to the planets who, when they get there, can speak only in eight-digit codes and binary numbers?

SORRY OM, PLEASE REPEAT, QRS, and QSD may soon depart the air—another victim of automation. Engineers of our Defense Electronic Products group have delivered to the Army a computer-like device which can copy hand as well as tape-sent Morse code. It can produce teletype copy at speeds up to 100 words per minute—and it can copy messages perfectly even where the quality of the hand-sent Morse code is poor.

The fifty-pound unit, which fits a standard 19-inch rack, is designed to operate 100-words-per-minute teleprinters. It can be placed in an existing communications link at any point where an operator would normally be required to monitor incoming code.

Key to the operation of the device is its logic circuitry, which responds like a human operator to the patterns of rhythms of incoming code, rather than to fixed dot-dash intervals of precise duration such as those received from tape code transmission, since this circuitry can be set for a wide range of sending speeds. It will allow for individual variations in code senders' "fists."

The logic circuitry also assures the reception of code even in the presence of severe electrical noise—either man-made or atmospheric—and it is capable of discriminating between two or more interfering signals on the same incoming carrier. By changing a few of the plug-in modules in the

Continued on Page 44

MOBILE UNIT FEEDS AN ALL-SPORTS TV DIET

WKBD-TV, the new all-sports UHF station in Detroit, has taken delivery of a custom-built mobile TV unit as part of its contract for more than \$650,000 in RCA broadcast equipment. The station began broadcasting January 10.

The mobile unit marks the first use in a vehicle of the new all-solid-state TR-4 television tape recorder. The vehicle also carries two 3-inch I.O. field cameras and audio and director's consoles, enabling it to operate on location as a complete TV tape production unit, according to John A. Serrao, General Manager of the Kaiser Broadcasting Company station.

When required, the vehicle's TV tape recorder can be remotely controlled from the studio so that, with the truck parked outside, the station has the use of the additional tape playback facilities. Mr. Serrao said sports events would be broadcast "live" whenever possible, with the help of seven RCA microwave systems. These systems will relay programs from such remote points as the University of Michigan at Ann Arbor and Michigan State University at East Lansing.

Two RCA tape machines in the studio provide recording facilities for delayed broadcasts. Other RCA equipment includes transistorized "live" and film cameras and slide and motion picture projectors.

The Kaiser station airs its programs from an RCA high-gain antenna atop a 1,000-foot tower in the northwest suburb of Southfield, and will use RCA's newest 30-kilowatt transmitter for UHF service. A typical winter program schedule shows a weekday "on-air" time of 6 p.m. with full evenings of high school and college basketball, wrestling, hockey, bowling and other "live" and recorded sports attractions.

Leonard Gostin, station engineer, checks TR-4.



TWO TOP RCA SALES POSTS ARE FILLED



John P. Shipley



Orton E. Wagner

Two pipe-smoking sons of the midwest, men who reach their negotiating best when the aroma of smoldering burley fills the room, have advanced their RCA sales careers. Early this year one of them moved into a key position in world-wide marketing; the other succeeded him in an important New York City post.

Orton E. Wagner, a native of South Dakota, has moved up to Manager, Broadcast and Communications Marketing for the RCA International Division. John P. Shipley, born in Nebraska, has succeeded him as Manager, New York Broadcast Office, Broadcast and Communications Products Division.

Mr. Shipley, who looks the part, gave serious thought during college to becoming an advertising man. But the communications field intrigued him and, when he became an RCA broadcast sales representative in 1960, he brought a background rich in useful experience.

After five years as a salesman in Michigan, Mr. Shipley has taken over as Manager of the Broadcast and Communications Products Division's New York Broadcast Office. In this capacity he supervises RCA broadcast equipment sales to networks and New York City radio-TV stations. His responsibilities also include sales of closed circuit TV and film sound recording equipment.

Mr. Shipley's first taste of broadcasting was gained as an A.T.&T. transmission man, a career that was interrupted by World War II service as a chief instructor of communications in the Army. After military duty he spent another four years helping to set up and maintain A.T.&T.'s radio and TV network facilities.

This led him to a job as a transmitter engineer at WOIC, later WTOP, in Wash-

(Continued on next page)

Mr. Wagner, with a stint as a broadcast station engineer and Korean War service behind him, joined RCA at Camden, N. J. in 1953 and was assigned to the broadcast antenna group as a product analyst.

His sales career in broadcast equipment began two years later when he was assigned to the Seattle office, a post he held until 1960. That year he became Manager of the New York Broadcast Office of the Broadcast and Communications Products Division.

The New York assignment brought Mr. Wagner into contact with network and station group management based there, and with various major users of closed circuit TV equipment. During his tenure the activity was expanded to include film sound recording equipment sales in addition to radio-TV gear.

In his new post with the RCA International Division, Mr. Wagner is responsible for all international sales of broadcast equipment, microwave, two-way radio, high-frequency communications equipment and other items in the Broadcast and

(Continued on next page)

... Shipley

ington, D.C. and, after two years, to New Britain, Conn., where he became Chief Engineer for the New Britain Broadcasting Company, at that time a part of NBC.

After five years, Mr. Shipley became Operations Manager for the Hartford-New Britain group stations. His responsibilities were extended to include, in addition to engineering, supervision of film operations, TV traffic, TV program and continuity acceptance operations.

When he started west in 1960 to begin his RCA sales assignment, Mr. Shipley went with instructions to survey Detroit suburbia for suitable golf links. For, in addition to being a golfer himself, Mr. Shipley heads a golfing family that includes a golfing wife and four golfing children. Now, back in the East with his clubs, he awaits the spring winds that will melt the snow from the fairways and dry the soggy greens.

... Wagner

Communications Products Division's line. His responsibilities also include international sales supervision of products designed and produced by RCA Industrial and Automation Products, Plymouth, Michigan. Mr. Wagner's home base is in Clark, N. J.

Mr. Wagner's broadcast experience was gained at WOW, Omaha, where he served as a station engineer for approximately three years. During the Korean conflict he was an Air Force First Lieutenant specializing in radar and the evaluation of mobile TV units for Air Force training purposes.

A native of Dell Rapids (pop. 1,650) in the Sioux country of his home state, Mr. Wagner was graduated from the University of South Dakota with a bachelor's degree in electrical engineering. These days he plots his grand strategy from bachelor quarters in a Central Park West apartment house in New York.

Newest camera for CCTV applications shows off its solid-state circuits for Janice Pennington.



QUALITY WITH LIGHT TAB KEYS NEW CCTV LINE

In late January RCA broke the news of its new line of professional TV equipment for the closed circuit market. The PK-301 solid-state camera shown here is the first item in the line which, in coming months, will grow to include other transistorized cameras, monitors, distribution amplifiers, switchers and other gear.

The new products are aimed at the potential CCTV user who, on the one hand, wants equipment of broadcast quality but can't afford it, and, on the other, refuses to accept the sacrifices in quality and reliability that come with many of today's low-priced systems.



The PK-301 is little, it's lovely, it's fight!

The PK-301 has moved into this void, carrying a modest base price of \$2,500 and a list of design features calculated to make it attractive to CCTV users in education, business, government and elsewhere.

It employs a 1-inch electrostatic-focus vidicon for pickup, measures but 6 by 6 by 10 inches and weighs a mere 16 pounds. Modular construction gives it great flexibility, providing as many as 16 different configurations such as battery operation and remote control. It operates from a 117-volt power source or 12 volts DC.

The camera has proved to be highly stable and capable of continuous operation over long periods without adjustment. Operating controls have been simplified in deference to the non-technical user. Controls include "brightness" and "focus" knobs and a "day-night" switch for optimum contrast during those periods.

TAPE RECORDERS GO ALOFT TO SPEED MAJOR STORY COVERAGE

Two RCA TR-22 television tape recorders made a flying round trip to London January 29-30. They rode in a jet plane that NBC News had converted to an airborne TV production center to bring viewers a fully-edited broadcast of the funeral ceremonies for Sir Winston Churchill.

NBC, describing the project as a "significant advance in electronic journalism," said it was the first time that tape of a major news event was edited into a TV news special in the air. Editing was done as the plane cruised at 600 mph on the return trip from London, with Correspondent David Brinkley viewing the pictures and writing and dubbing in his narration. The program was aired at 4 p.m. January 30 as the big intercontinental jet touched down on schedule.

The TR-22s were lashed down with steel cables in an area of the plane that had been cleared of seats. Insulating material was packed around them to reduce shock from vibration and the plane's movement in the air. Lashed down nearby were two generators needed to convert the plane's 28-volt, 400-cycle power to 110 volts, 60 cycles, for the tape machines.

In addition to the recorders, which were partially dismantled to clear the plane's door, the flying production center included a special sound-proof booth. Mr. Brinkley sat in it to record his narration without interference from the roar of the engines.

As the ceremonies began, the NBC plane parked at the London airport got a "clean feed" (sound of crowd and traffic movement, but not the BBC commentaries) from the British Broadcasting Corporation. The recording totaled three hours and was edited down to one hour to fit the broadcast period.

When the chartered plane, a TWA Star-Stream 707-331, landed at John F. Kennedy International Airport in New York, it was met by an NBC mobile tape transmitting unit which relayed the program by microwave directly to the network.

Installation of equipment aboard the big craft was supervised by Thomas H. Phelan, Manager, Technical Facilities and Maintenance, for the NBC television network. Eight TV engineers were aboard during the round trip, along with the production staff, film editors and a full flight crew.



Three hours of tape were edited to one hour.

The TR-22s were securely lashed in place.

Correspondent Brinkley checks playback as jet streaks toward New York.





Seats were removed from the TWA Starstream to make room for the tape machines.



Generators converted plane's power to 110.

Flying tape center gets final checkout before departure for London where TV coverage of Churchill funeral ceremony was recorded.



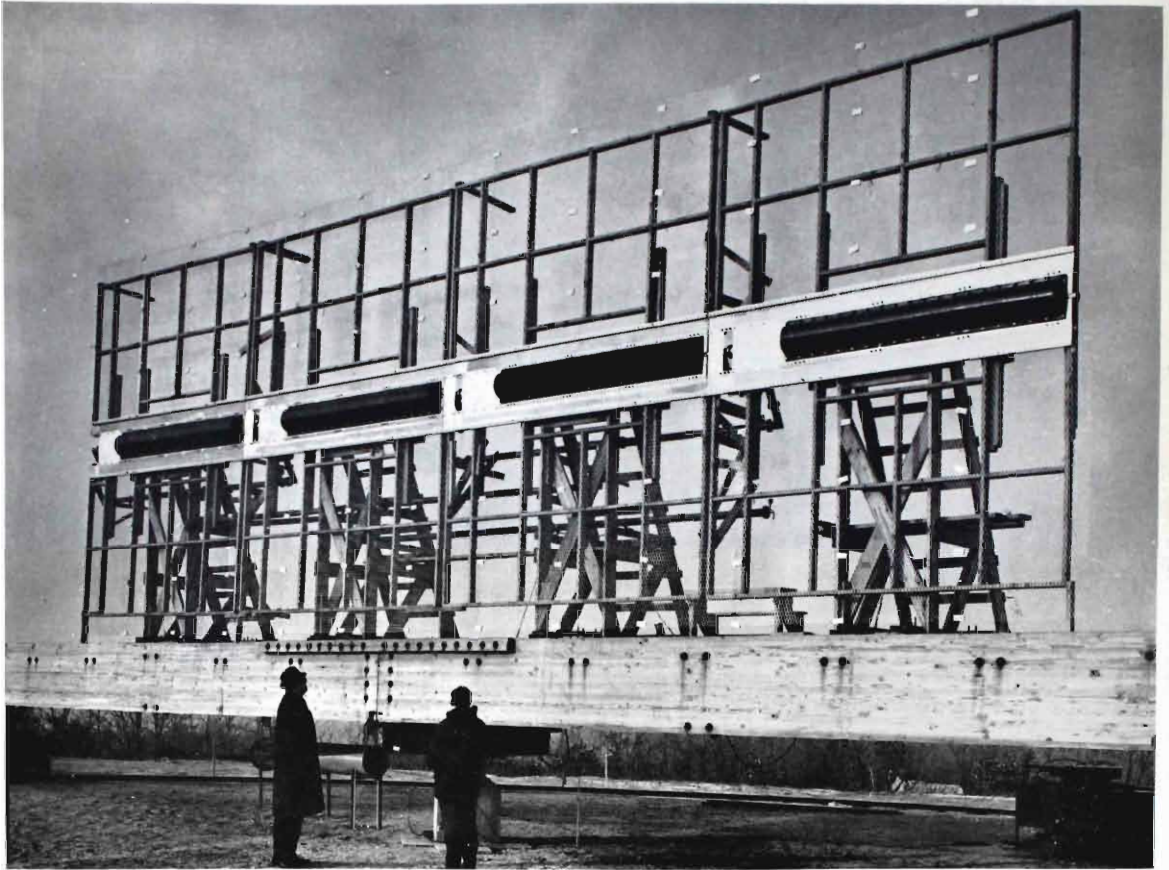

One-half of WNJU's antenna is tested at RCA's proving grounds; screen is not part of the system.

ANOTHER TENANT PACKS FOR MOVE TO EMPIRE STATE TOWER

A unique pylon antenna system will radiate WNJU-TV's signals when the new station for the metropolitan New York-New Jersey area begins broadcasting in color and black-and-white on Channel 47 this spring.

The accompanying photograph shows the system in final checkout at RCA's 42-acre antenna test site at Gibbsboro, N. J. The system will be installed on the Empire State Building 1,200 feet above street level.

Eight tubular panels, joined electrically to produce the signal pattern for WNJU's four-state viewing area, make up the system. Four panels in a vertical array 52 feet

high will be mounted on the building's north side, the other four on the south side.

As with conventional pylon antennas, energy is radiated through a series of slots running lengthwise in the antenna's surface. The size and arrangement of the slots control the coverage pattern of the broadcast signal.

The aluminum screen shown in the photograph is not part of the WNJU system but is used to simulate a section of Station WNDT's antenna now in place on the building. Installation of the WNJU antenna will require cutting the screen and mounting the tubular panels behind it.

The WNJU antenna design was the outgrowth of an engineering study, sponsored by the Empire State, to determine how additional TV stations could broadcast from the building without interfering with those already there. The study determined that at least six more broadcast antennas could be accommodated.

New York channels 2, 4, 5, 7, 9, 11, 13 and 31 now share the Empire State as a common antenna site, an arrangement unequalled in the television world. Broadcasts are radiated over a four-state area, reaching a potential audience of 15 million viewers.

WPIX, New York, has contracted for approximately \$400,000 in RCA broadcast equipment, including the new TK-27 color TV film system, as part of a modernization of its technical facilities. It thus becomes the second New York City station to order the new four-channel camera chain. WOR-TV had ordered a TK-27 earlier. The WPIX purchase also includes a TP-66 film projector and two 25-kilowatt transmitters.

The transistorized film system is scheduled for installation in the WPIX studios at 220 East 42nd Street, New York, while the transmitters will replace the station's original transmitter in the Empire State Building. The original unit was the first commercial-type TV transmitter produced by RCA and has been in service since WPIX began broadcasting in June 1948.

The new transmitters will be used "on-the-air" alternately, according to the station's plans, thus permitting normal maintenance on the idle unit during the broadcast day. The arrangement provides for instantaneous switching between the two transmitters.

The transmitters incorporate the latest advances for efficient and economical operation. Overall size of TV broadcast equipment has shrunk over the years so that the two new WPIX transmitters will occupy only about the same space as the original single unit.

WPIX PICKS 4-TUBE CAMERA IN COLOR MOVE



In smiling accord on new equipment contract are, from left, Fred M. Thrower, WPIX Executive VP; Otis Freeman, VP, Engineering for station, and Charles H. Colledge, RCA Division VP.

Hard hats hash over 40-foot extension to tower.



NATION'S FIRST COMMERCIAL MICROWAVE LINK RE-EQUIPPED FOR HIGH-CAPACITY SERVICE

A communications milestone was reached in Mt. Laurel, N. J. recently as the final relay station in the nation's first commercial microwave system linking New York, Philadelphia and Washington—was re-equipped for high capacity service.

RCA's new MM-600 microwave gear replaced the original CW-1 units, in operation since 1946 when Western Union began message service via microwave. The carrier uses the MM-600 equipment in 236 stations of its 7,500-mile trans-continental network which was "fired up" for the first time last November. The system has a capacity of 2,400,000 words per minute and will handle high-speed data, alternate record-voice, facsimile and other services. Increased capacity is twenty-fold, from the original 30 voice channels to the 600 channels provided by the new RCA equipment.

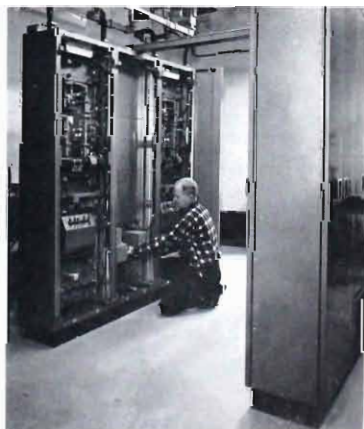

RCA's 600-channel gear links coast to coast.



TV TAPE PLAYER

Designed For Playback of All Standard
Quadruplex Tapes, the TR-3 Serves
Broadcast and Closed Circuit Users

Up to this time, television tape machines have been designed to include both the recording and the playback function. A need has existed for a single function machine, one that would encompass only the playback application. Since the total machine can perform only one of its dual functions at a time, it is well within the interests of efficiency and economy to provide a separate playback machine.

Introduction of the TR-3 TV Tape Player represents a step forward in the continuing effort of RCA to fill the broadcaster's needs as well as to serve the requirements of educators and other television users.

The TR-3 provides an economical means for playback of video tapes. Its operation may be likened to a motion picture film projector. In the same way that film projectors are used to put programs on-air, or to screen commercials in the client room,

so the Player may be used either for on-air broadcasts or for previews of taped programs and commercials.

Quadruplex Standards

The TR-3 is a compatible machine. It will play all standard broadcast tapes. This means tapes made on quadruplex recorders to FCC on-air standards. Thus the Player serves broadcaster's needs, also high-quality closed circuit applications. It will play monochrome and color tapes.

Two-Speed Operation

Built-in circuits permit choice of operating speed: $7\frac{1}{2}$ or 15 inches per second. Playback time at 15 IPS is 60 minutes, at $7\frac{1}{2}$ IPS it is 120 minutes. Use of slower speed cuts costs of tapes in half.

Description of Features

Standing but 66 inches high and occupying less than two square feet of floor space, the Player is mounted on casters for easy

placement in either a fixed installation or a mobile unit. Modern styling, together with two-tone finish of space and horizon blue, make the instrument as attractive as it is useful.

Controls are placed on a handy sloping panel at waist height. Tape reels are loaded and unloaded by sliding on and off at convenient chest height.

Electronic circuits are highly stabilized so that frequency adjustments are not necessary, and the machine may remain unattended while being operated from a remote viewing area, or being used to present an on-air or closed circuit program.

Design follows the tradition set by RCA engineers in the deluxe TR-22 TV Tape Machine, which has literally become the world's standard for the finest broadcast quality in television tapes. As a result, picture quality attains the same high standard of perfection.

FEATURES OF THE TR-3 TV TAPE PLAYER

- Compatible—plays any standard tape.
- Built-in, 2-speed operation.
- Designed for remote control.
- Pre-set, semi-automatic operation.
- Interchangeable, transistorized modules.
- Modern styling, 2-tone blue with silver-grey finish.
- Only 66 inches high, occupies less than 2 square feet floor space.

APPLICATIONS FOR THE TR-3 TV TAPE PLAYER

- Provides broadcaster with additional source for on-air material, for editing, and relieving pressure on recorders at relatively low cost.
- For agencies and station reps, it provides a means for checking and for presenting commercials to clients.
- It is a low-cost highly-effective selling tool.
- For closed circuit users, it may be integrated into the system and used to present taped programs.



FIG. 1. First step in operation of TR-3 Player: LOAD THE TAPE.



FIG. 2. Second step in operation of TR-3 Player: THREAD THE TAPE.



FIG. 3. Third step in operation of TR-3 Player: PUSH THE BUTTON.

Furthermore, the TR-3 Player is designed to accommodate a full complement of accessory equipment within its own enclosure, to make it more useful to those who may need the additional features provided by the accessories.

Broadcast Applications

For broadcasters this new TV Tape Player has many important uses, making it possible to expand tape facilities with but a modest investment. The Player may be employed for broadcasting or for in-house presentations. This flexibility relieves the usually overloaded schedule on the regular recording facility, and enables the station to engage in many more sales promotion efforts.

Sales Promotion Tool

Having a Player available for use in the client's room for screening of tapes, constitutes a first-rate sales advantage. In this way, it is used much the same as a projector for screening of filmed commercials. Moreover, this assists station personnel engaged in planning production to get results faster—without tying up the regular video recorder, or getting into a great deal of overtime.

Facilitates Station Operation

Some broadcasters will be intrigued with the possibilities of integrating film and tape facilities, which this Player makes conceivable. Just as TV film projectors are employed in the film room to put programs and commercials on air, so the Player may be installed (in the same area) for this identical purpose. Placing film and tape machines in the same area simplifies station operation, opening up the way for new and more efficient procedures. This also permits separation of the recording (production) and broadcasting (or previewing) operations, which is highly desirable.

Agency and Rep Applications

Since the tape player can be employed much the same as a film projector, it seemed no more than logical to expect that a station representative would be one of the foremost to find the device useful. Peters, Griffin and Woodward has proved practical worth of the Player in short order. Installed in the film projection room, the output is fed to the client's board room. Here tapes of programs and commercials are presented on a regular television receiver in order to get the natural effect of what the average viewer sees.

Military and Educational Uses

For closed-circuit or open-circuit links the Player provides a most economical

means of offering lectures, demonstrations, and teaching via television. Since it is a compatible machine, all the taped material produced according to standard SMPTE practice (quadruplex recording) may be programmed using the Player. In other words, for high quality work in accordance with SMPTE standards, this is the most economical method.

Multiple Players Cut Costs

In the case of multiple presentations, that is, different programs at the same time (or the same program with different audio), the use of a group of tape players saves considerable space and expense. The Player occupies an area only 22 by 24 inches, so that several may occupy the space required by a standard recorder. Further, use of the Player when only the playback function is required, cuts costs of installation approximately in half.

TR-3 Simplicity of Operation

No particular skill or long period of training is required to operate the Player. It is only slightly more complex than operating a film projector. In both machines, the general procedure is quite similar. The Player is loaded with a reel of tape as the projector is loaded with a reel of film. The tape is threaded through the Player in much the same manner as film is threaded through the projector. Thereafter, pushbuttons are used to control operation of the machine. The pictures from the tape may be viewed on any television monitor or a regular TV set.

Ease of Servicing

Accessibility of parts is emphasized throughout, the interior being available from either front or rear. In the event the Player is placed against a wall, it is readily moved away for servicing by means of the built-in casters. Modular construction speeds up maintenance, because the standard modules can be replaced in a matter of a few minutes should trouble arise. Filtered air is circulated throughout the Player to prolong life of components and to increase reliability.

New Look Design Features

The TR-3 Player reflects the advanced design techniques of transistorization, modularization, and standardization. Transistorized circuits require less space, are more reliable. Standard circuits are compatible with those of RCA's Deluxe recorder. This standardization reduces costs, makes operation uniform, and simplifies servicing. RCA New Look design has resulted in a Player with the fine performance that results from achieving full compliance with all broadcast standards.

PGW Uses TR-3 Player as Selling Machine

Interview with MR. LLOYD GRIFFIN, President-Television

Peters, Griffin & Woodward, New York City

"Our TR-3 TV Tape Player is a selling machine. It's used by our salesmen to help them sell, just as computers are used in agencies as machines to help media people come up with the right answers. Our TR-3 is available in operation any time, day or night. Our 'colonels' use it at luncheons to audition new programs. They show agencies, advertisers and prospects new programs, local talent, new personalities, new markets and station facilities.

"Client stations use our TR-3 to audition new tapes for PGW salesmen. Their sales managers talk 'live' this way to explain all about new programs, in their own words, just as if they were here in person. Then they present the programs on tape. In this way, it looks just like it looks on the air.

"Recently WTJV in Miami sent a tape to show their new idea in station breaks. This consists of views around the city to make viewers' mouths water for the wonderful re-

sort. People and places all come through just as they are. In this way, a station can present new ideas fast.

"Another station, KSL-TV, uses tape to show their entire market and distribution pattern to our salesmen. The General Manager of this station made the tape, doing the commentary himself, and included excellent photos of the market.

"We have had quite a few requests from advertisers and agencies to use our facilities for screening their commercials. Naturally we're always glad to make our shining new TR-3 available for this purpose.

"Even radio presentations are now being made on tape via our TR-3 so we can see the personalities! So what with screening and auditioning programs on air for our people and advertisers—using it as a selling machine to show program availabilities, our TR-3 is kept pretty busy."



FIG. 4. Mr. Lloyd Griffin, President-Television, at TR-3 Player in PGW projection room.

FIG. 5. Staff conference in PGW client room for viewing playback of TV tape program.

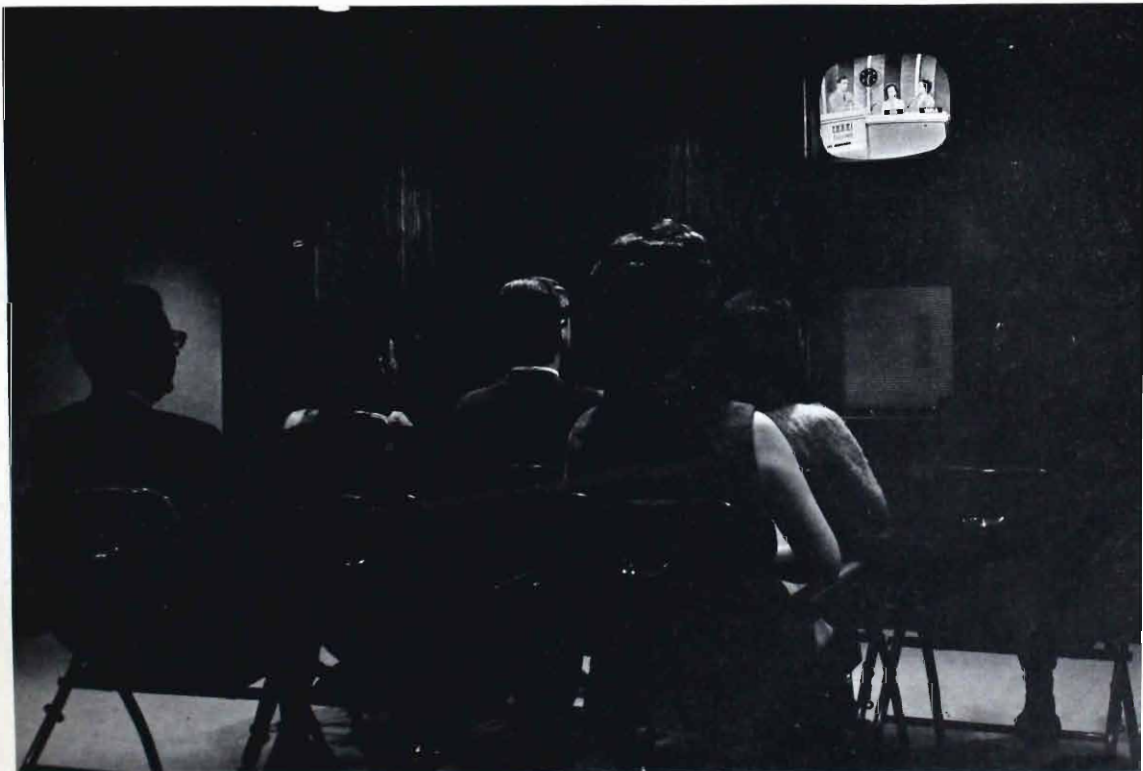

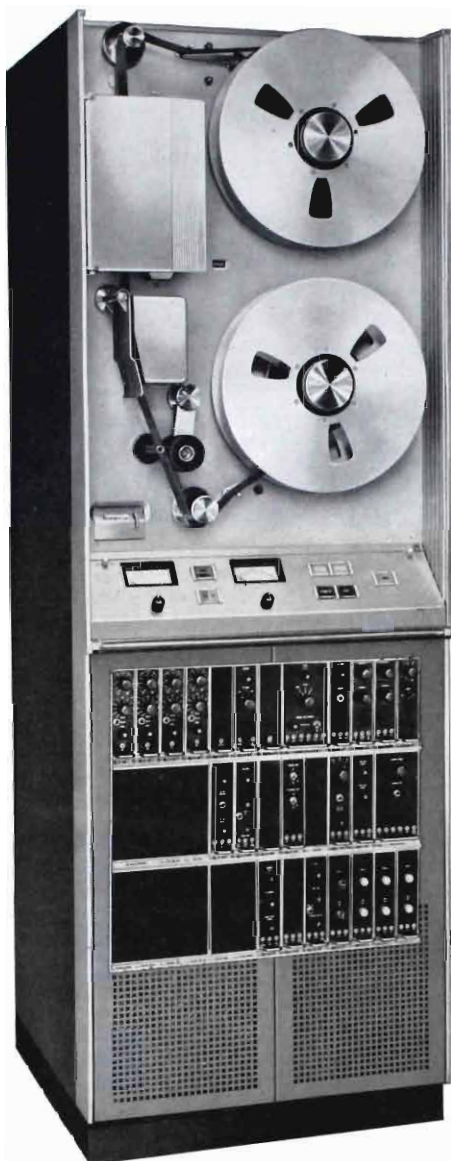

FIG. 6. TR-3 TV Tape Player, with bottom doors removed to reveal the modular construction.

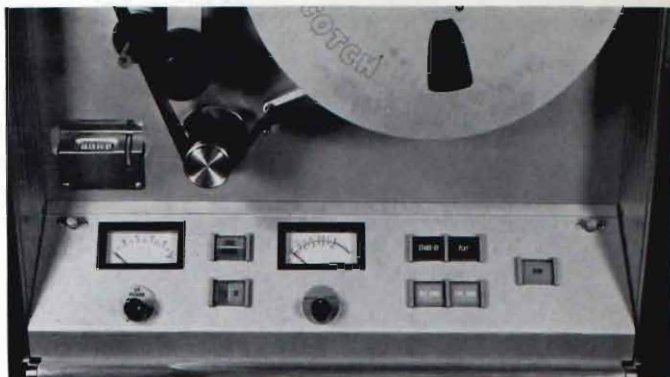

FIG. 7. Close up of operating panel.

GENERAL DESCRIPTION

basically the TR-3 may be divided into four major areas

1

TAPE DECK—It contains the major mechanics of the system, the transport mechanism and the reels.

2

CONTROL PANEL—It contains push-buttons for standby, play, forward, rewind, a 2-speed switch, and a stop switch. Here also are indicating meters.

3

MODULE BANK—This contains the servo and video electronics necessary to drive motors and operate the system.

4

POWER DECK—Included are the power supply, the blower, circuit breakers, and connector panels.

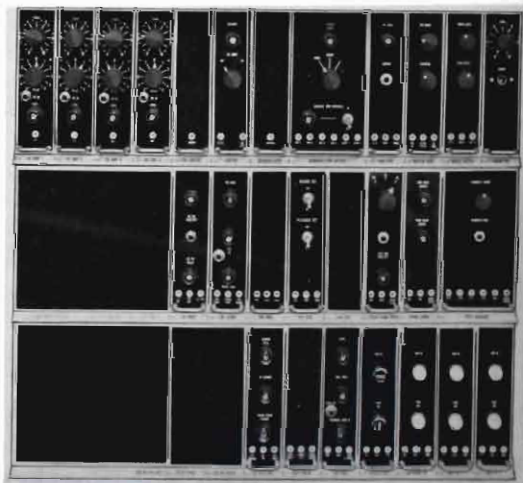

FIG. 8. Close up of module bank. Blank spaces are for accessories.



FIG. 9. Power deck of TR-3. At right is connector panel. At left is power supply.

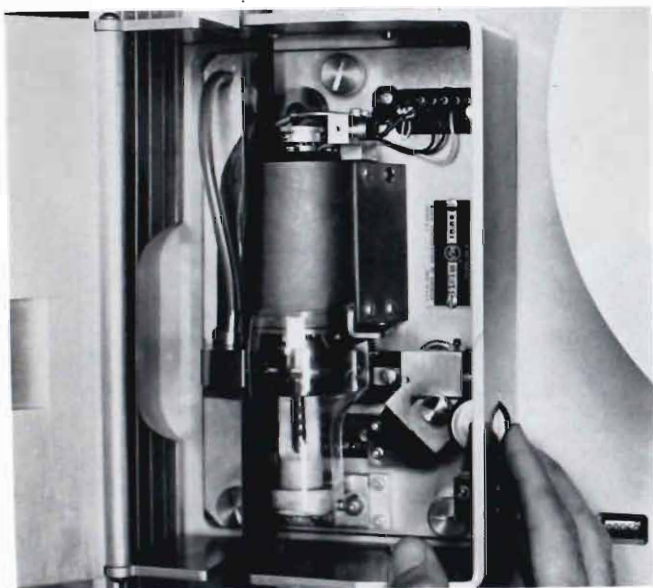

FIG. 10. Skewing adjustment of TR-3.

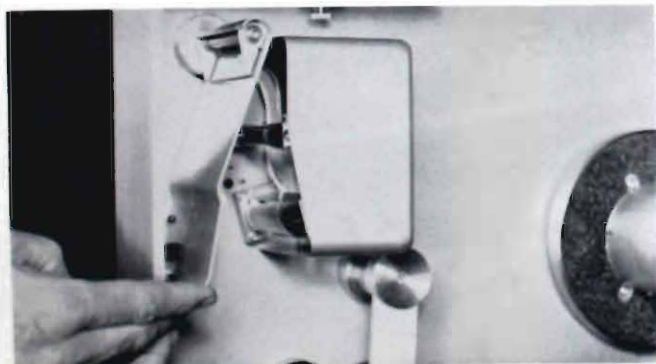

FIG. 11. Audio head of TR-3.

Switchable Standards

The TR-3 Player is available in 50-cycle and 60-cycle models. The 50-cycle model is equipped for operation on international standards. To change from one standard to another, the operator merely moves a switch knob to the desired position. Master circuitry provides instant changeover from 525 to 625 to 405 TV line standard.

Available Accessories

Space has been provided in the Player for accommodating a full line of accessory equipment. These accessories are designed as modules which may be plugged into the Player. No external racks or mounts are necessary to incorporate the following group of optional accessories.

Pixlock—This permits the machine to act as a source of picture signal for special effects, supers, or non-composite switching.

Monochrome ATC—This Automatic Timing Corrector will remove any of many familiar picture blemishes, such as: Residual jitter, quadrature errors, skewing, scalloping.

Color ATC—Used in conjunction with the foregoing, this accessory provides for playback of color tapes in original full fidelity of picture.

Remote Panels—These permit operation of the Player from a remote location (for example, the Player may be in the projection room while operation is controlled from the client's room).

Versatile Performer

A valuable supplement to present facilities, the TR-3 Player delivers the same high-quality picture signal as the RCA deluxe machine. For the broadcaster, it's an additional signal source for on-air use. Employed for customer previews, sales promotion, or editing, it releases recording equipment at relatively low cost. For agencies and station reps, it's an excellent way to show tape commercials and programs to clients. It's a low-cost highly-effective sales tool. For closed circuit users, the Player may be integrated into existing systems and employed to present taped programs. In any playback application where standard broadcast quality tapes are utilized, the TR-3 will serve more efficiently and economically.

WBRE-TV INSTALLS SILICON RECTIFIER SYSTEM TO UPDATE TV TRANSMITTERS

by CHARLES SAKOSKI, SR., *Chief Engineer, WBRE-TV*
and
HAROLD C. VANCE, SR., *Manager, Sales Engineering,*
RCA Electronic Components and Devices

WBRE-TV, pioneer superpower UHF television station of Wilkes-Barre, Pennsylvania, added to its long list of "firsts" by becoming the first station to install the new RCA silicon rectifier system type CR-252 which replaces the mercury vapor tube rectifier originally furnished with their RCA TTU-25B transmitter.

Advantages of Silicon Rectifiers

Among the advantages of silicon rectifiers are small size, insensitivity to normal temperature changes, elimination of "arc-backs" and rectifier hash and, in properly designed circuits, extremely high reliability. During the past several years practically all new transmitter designs have employed silicon instead of tube rectifiers.

Systems Approach Used

As a part of their program of continuous modernization, WBRE-TV asked RCA semiconductor engineers to design a complete silicon rectifier to replace the original main plate supply tube rectifier. Preliminary studies quickly showed the desirability of employing a "systems" rather than a "plug-in" approach, in order to take full advantage of the characteristics of silicon rectifiers.

The systems approach allowed the rectifier circuit to be changed and the interphase transformer eliminated. AC and DC transient suppression circuits were designed to meet the specific requirements of the rectifier system. It is important to protect rectifier diodes against high voltage transients if the utmost in reliability is to be obtained.

This new solid state rectifier was designed by engineers of the RCA silicon rectifier department at Mountaintop, Pennsylvania. They worked in close cooperation with the RCA transmitter engineers who had designed the TTU-25B transmitter. The new unit is housed in the same transmitter cabinet that originally housed the tubes and filament transformers of the tube rectifier.



FIG. 1. Charles Sakoski, Sr., WBRE-TV Chief Engineer, holding one of the silicon rectifier stacks used in their new high voltage rectifiers.

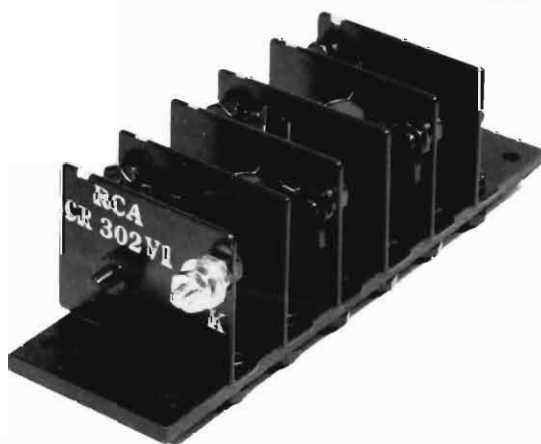

FIG. 2. Close-up of silicon rectifier stack, CR-302V1, a product of RCA Electronic Components and Devices Division, Somerville, N. J.



FIG. 3. Entrance to new office and studio building of WBRE-TV, Channel 28, Wilkes-Barre, Pa.

Each silicon diode is mounted on an individual cooling fin and has an integral R-C network to equalize both the steady-state and the transient reverse voltages across the diodes.

No Interphase Transformer

As a part of the redesign, the plate transformer secondary windings were re-connected from a 6-phase, double-Y connection,

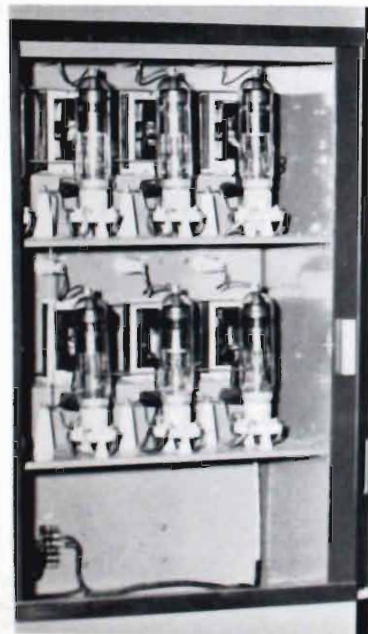

FIG. 4. Front view TTU-25B rectifier cabinet showing original tube rectifier.

with an interphase transformer, to a 6-phase, delta, double-way connection which eliminates the interphase transformer.

Ample Safety Factors

The nominal dc plate voltage requirement of the TTU-25B is 8.5 kv. The silicon rectifier stacks installed have a considerable safety factor, being rated at 18 kv repetitive peak and 21.6 kv single peak. In addition, the transient suppressors substantially reduce the peak values of the transient voltages.

The dc plate current requirement of the transmitter is 11 amperes. The silicon rectifier used has a rating of 13.4 amperes.

Only Three Hour Changeover

Advance preparation and careful planning reduced the time required for the actual changeover to less than three hours.

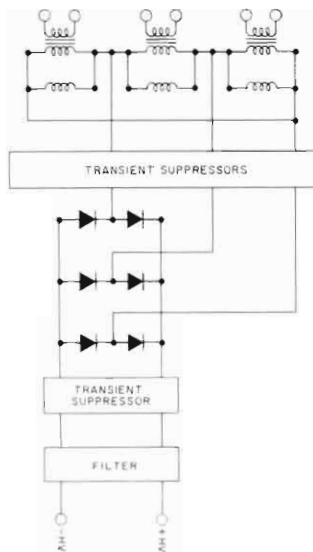

FIG. 5. Modified rectifier circuit using silicon rectifiers (simplified schematic).

This was accomplished during part of the normal early-morning shutdown period on Sunday, August 30, 1964.

New mounting holes were drilled ahead of time where possible and all new wires and cables were cut to length, dressed and ready for connection to the proper terminals.

The original rectifier required six high-voltage cables between the plate transformers and the rectifier cabinet. Since only three are required with the new circuit, there now are one active and one spare cable between each of the three transformers and the rectifier cabinet.

Heat Control Eliminated

Silicon rectifiers are relatively insensitive to fairly wide temperature changes. This permitted removal of the original temperature-control heater, blower and thermostat from the cabinet. The exhaust fan was retained. Under these new conditions the normal cubicle temperature runs about 90°F (32°C). Unlike tubes, no "warm-up" time is required by silicon rectifiers.

Improved Reliability

Operating results of the new rectifier have been highly satisfactory. It is estimated that the reliability of the transmitter has been improved by at least 80 per cent. The new system has operated through four or five lightning storms with no trouble. The engineering staff of WBRE-TV recommends this silicon rectifier system with no reservations.

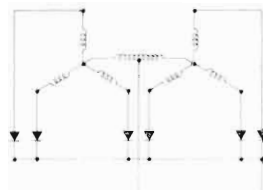

FIG. 6. Original WBRE-TV rectifier circuit using tubes (simplified schematic).

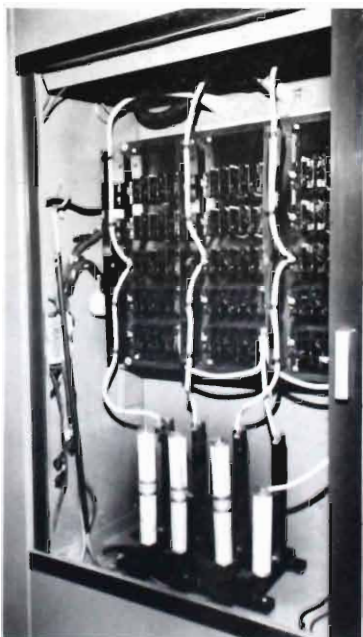

FIG. 7. Front view TTU-25B rectifier cabinet at WBRE-TV, showing new silicon rectifier stacks.



UNIQUE FEATURES OF THE NEW RCA COLOR FILM CAMERA

Completely Transistorized, Uses Electrostatic Vidicons
with 1½" Vidicon in Luminance Channel

by D. M. TAYLOR
TV Camera Engineering

The TK-27 is a four channel camera, employing a vidicon in its monochrome or luminance channel which is entirely separate from the three vidicons in the red, green and blue channels.

Exhibited at last year's NAB and now in production the TK-27 Color Film Camera is the latest in an all new and advanced line of solid state cameras for color and monochrome TV.

It is not the only four channel color film camera available, but it is the only one employing *electrostatically focused vidicons* with a 50 per cent larger 1½-inch vidicon

tube in the luminance channel. It's the only *completely transistorized* color film camera available, and the only one with a power consumption of *less than 200 watts*. It's the *most compact*—taking only three square feet. It is the only four channel color film camera with N.A.M. monitoring to help avoid transmitter overload and undesirable effects at the receiver. These are only the first few of a list of more than 20 *unique* features offered by the new TK-27 for color film and slides.

Advantages of Electrostatic Focus

The four vidicon pickup tubes, the only

tubes used in the TK-27, are all electrostatic focus/magnetic deflection types, highly suited for use with solid state circuitry. Being electrostatically focused, they require no coils, consume negligible power, are independent of high voltage variations. Without the focus coils, heat is eliminated. Even the deflection power and heat dissipation in the deflection coils is substantially lower than in a magnetically focused tube. Heat in the camera head, which in all cameras is the principal cause of rise in dark current, has been reduced by at least 40 per cent in the TK-27 through electrostatic focus.

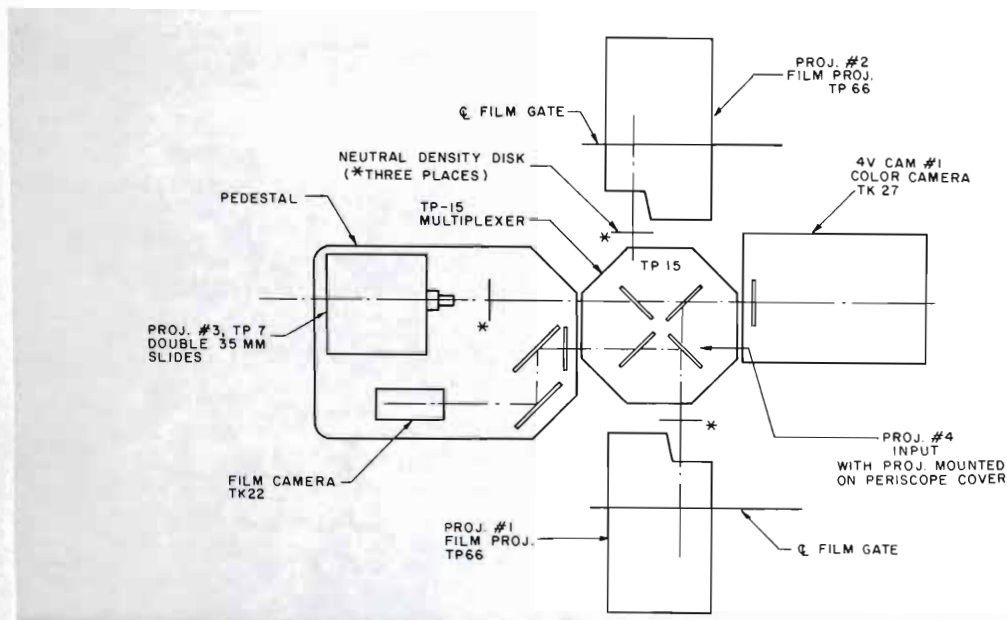

FIG. 1. New TK-27 Color Film Camera multiplexed with TP-66 16mm Film Projector (center) and TK-22 Monochrome Film Camera. Left. Rotatable monitor on top TK-27 is an optional accessory.

FIG. 2. Plan view of typical multiplex arrangement of two film projectors and a slide projector which may be optically projected on either the TK-27 or TK-22.

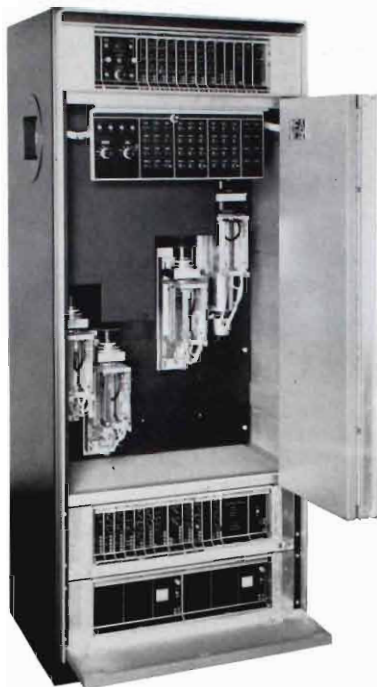

FIG. 3. TK-27 center compartment houses the four vidicons, optics (beneath cover) and vidicon setup control panel. Along top are plug-in, transistorized circuit modules associated with camera head. Camera auxiliary modules (shown mounted in bottom compartment) are usually rack mounted.

Larger, Higher Resolution Pickup Tube

The luminance channel employs the RCA Type 8480 vidicon which is 50 per cent larger than any used yet in color film cameras. This tube, which provides a correspondingly larger picture surface has twice the signal output of one-inch types, resulting in s/n ratio increase of 6 db. Signal-to-noise ratio is also improved due to excellent aperture response, minimizing need for aperture correction. An extremely stable high peaking adjustment is assured by the constant input impedance of the input transistor, which is mounted on the vidicon to minimize input capacitance. High resolution capability, not only in terms of limiting resolution, which is 800 lines in the center and 700 in the corners, but also in improved response to all pic-

ture detail information results in unusually sharp film and slide reproduction.

Completely Transistorized

The TK-27 employs compact plug-in circuit modules, the majority of which are interchangeable with those in the TK-22 and TK-42 cameras. Employing built-in test circuits and jacks, these modules are easily withdrawn for service or replacement. A module extender is available that permits test of the module without removing it from the circuit. Interchangeable modules provide maximum accessibility of components. They also result in greater circuit familiarity and easier maintenance. The degree of interchangeability between the modules of the TK-27, TK-22 and TK-42 equipments is illustrated in Fig. 4.

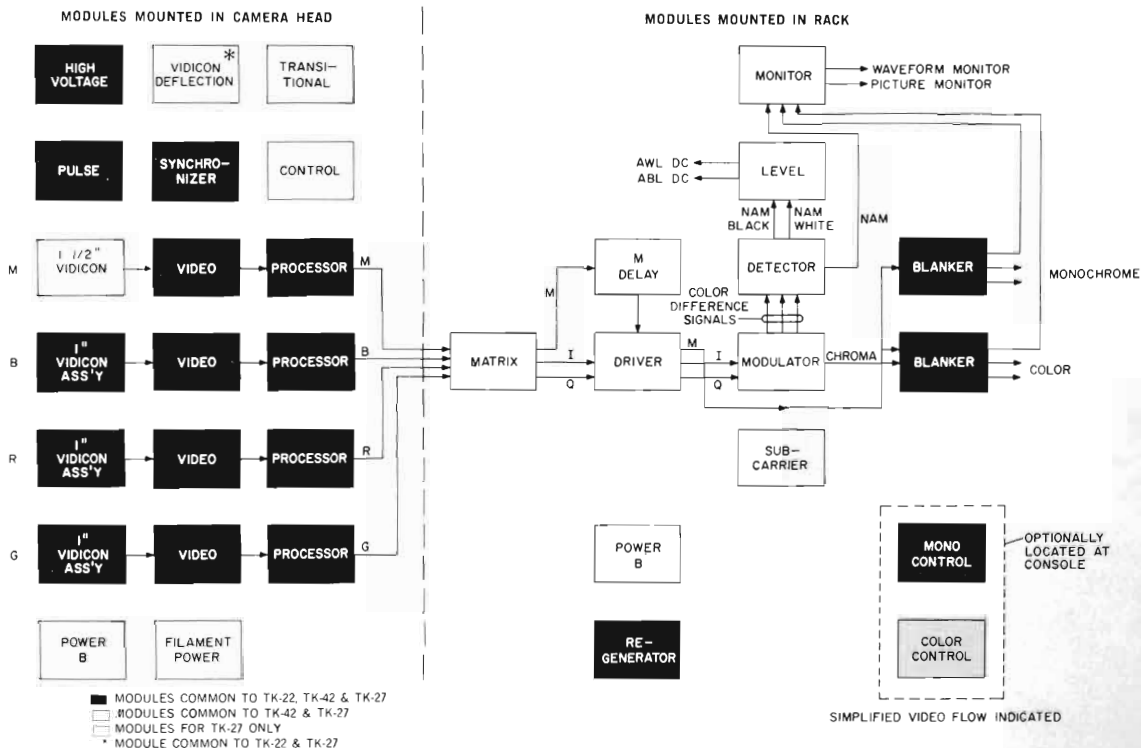

FIG. 4. Block diagram showing modules used in TK-27 and degree of interchangeability with those of TK-22 and TK-42 equipments.



FIG. 5. Camera plug-in modules.

MODULES IN CAMERA HEAD

CONTROL—Contains switches and other circuitry for controlling viewfinder, optical black, gamma, mono polarity reversal, 3V 4V, electronic "cap" and indicators.

PROC—Processor clamps video signal and inserts gamma, black clipping, white clipping. Has circuitry for manual and automatic black, and automatic sensitivity.

VIDEO—Amplifies signal from preamplifier and provides aperture compensation, remote gain, manual and automatic gain, polarity reversal.

PULSE—Generates black and white pulses, pulses for horizontal drive stop, gating test, and automatic circuits.

SYNCHRONIZER—Takes sync fed to camera head and horizontal drive stop pulse from the Pulse Module and generates and distributes vertical gating, vertical drive, timing pulse, and horizontal drive. Contains the camera head circuits for automatic time delay compensation and also clips and amplifies sync for use in other modules.

DEFLECTION—Provides horizontal deflection, vertical deflection signals for the 1½-inch vidicon and

the Transitional Module. Also contains vidicon protection in case of scan failure.

TRANSITIONAL Using signals from the Deflection and High Voltage modules, it provides horizontal and vertical deflection signals, and regulated voltages to the three 1-inch vidicon assemblies.

H.V. Contains circuits for generation of high voltage used with the vidicons, the DC filament voltage to the 1½-inch vidicon and the reference voltage to operate transistor de-couplers on other modules. Vidicon blanking and target voltage ranges are set in this module.

MODULES IN AUXILIARY POSITION

REGENERATOR—Regenerates sync, blanking and clamp pulses in addition to having the rack portion of the circuits for the automatic horizontal drive advance which compensates for camera cable and encoder delays.

BLANKER—Adds final blanking to the video signal, contains a multiple video output line driver with sending-end termination and has switchable sync addition to the output video signals. Also contains a single line driver with sending-end termination which can be remotely switched to the line, an external signal coming from a loop-thru input or a combination of the line and the external signal.

MONITOR—Contains the line driver amplifiers for the feeds to the CRO and monitor, and amplifiers for the signals to the line drivers. Regenerates blanking and clamp pulses and system blanks the BRGM signals. A test switch is included which allows setting up of the encoder using only the CRO signal.

DETECTOR—Accepts the monochrome and color difference signals and converts them into receiver

Br, Rr, and Gr signals. It non-additive-mixes these signals for white and black and switches between the non-additive-mix (NAM) white and black signals to form a single NAM signal (similar to a monochrome camera signal) used for level monitoring. The individual NAM white and black signals are used in the automatic white and automatic black control systems.

SC (SUBCARRIER)—Supplies the quadrature sub-carrier signals to the Modulator and generates the sampling bursts required by the automatic carrier balance detectors.

MODULATOR—Modulates the I and Q color difference signals to produce the chroma signal with automatic carrier balance. Generates a gating signal to ungate the Blanker Module during burst time. Provides the color difference signals to the Detector Module.

DRIVER—Band limits the I and Q signals, inserts burst flag into the I and Q for burst generation, and sends these signals to the Modulator. Amplifies M signal and drives M Delay Module. Inserts delay into I signal to match Q filter delay.

MATRIX—Matrixes B, R and G signals into I and Q. Contains the relays and amplifiers used in monitoring the individual M, B, R and G signals and has provisions for tying the B, R, and G signals together for white balance adjustment of the encoder.

BAR GENERATOR—From sync and blanking it generates B, R and G pulses which are used in conjunction with the other modules form a standard non-split modulated color bar pattern of either 100% or 75% level as selected by a front panel switch.

LEVEL—Detects the NAM white and NAM black signals and forms DC voltages used in the feedback loops for automatic white and automatic black level control. Also provides the gating required for optical black operation of the camera.

M DELAY—Delays the M signal to match the Q filter delay.

POWER B—Develops regulated plus and minus low voltage DC for use in all other modules and supplies an AC low voltage to the Filament Power Module.

FIG. 6. Camera Auxiliary plug-in modules.

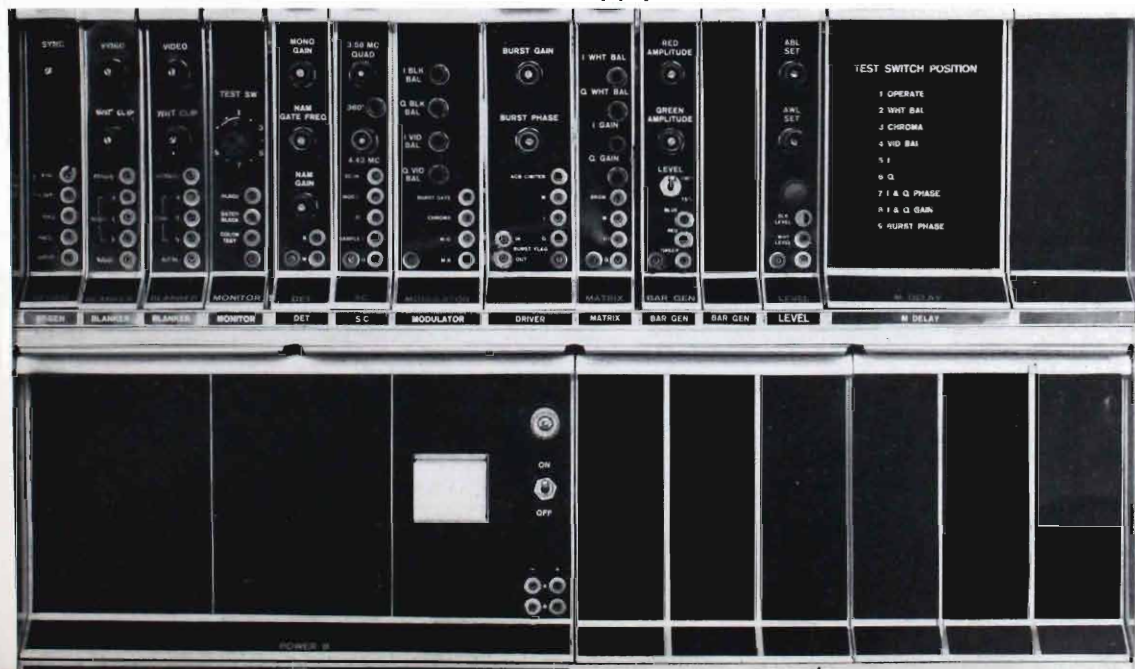

Monitoring Technique

The common practice in monitoring any TV film system, monochrome or color, is to adjust and calibrate the amount of light striking the pickup tube so that the electrical signal generated by the pickup tube has the right amplitude as seen on a CRO waveform monitor. A typical waveform for monochrome operation is shown in Fig. 7. Using this display as a guide, the operator adjusts the equipment and effectively maintains the peak value of the waveform signal at the 100 per cent level. In 3-V color systems, the three color signals at the input to the colorplexer are simultaneously displayed, adjusted and monitored to maintain the highest at the 100 per cent level as shown in Fig. 8.

Monitoring of the four-tube color camera, however, must be handled differently because of the presence of the separate luminance channel.

This is illustrated by composite waveforms. For example, when a 3-V camera, in which the three color signals are properly adjusted for the 100 per cent level, scans a vertical bar pattern comprising a white bar and fully saturated yellow, cyan, green, purple (or magenta), red and blue bars, the composite signal would be as shown in Fig. 9. But, a four tube system displaying simultaneously the blue, red, green and M (luminance) signals, and adjusted, as in Fig. 10, in the same manner as for the 3-V camera will produce the undesirable composite signal seen in Fig. 11.

The differences in amplitudes between the Fig. 9 and Fig. 11 waveforms results from the gamma or transfer characteristics of the monochrome pickup tube. The serious consequences of this change in video signal are as follows: 1) Distortion of the yellow and cyan colors displayed on the color receiver; 2) An electrical signal at the receiver kinescope as much as 25 per cent higher than normal; and 3) Visibility of the color subcarrier at the receiver because of rectification effects at the kinescope, especially in wideband receivers.

Single Waveform Display

To avoid this in the TK-27 camera, the M signal and color difference signals (see Figs. 4 and 12) are converted into 3 signals (B_r , G_r , R_r) identical to those in the color receiver, and in each channel of which the M-signal is truly represented. These three signals are then combined by non-additive-mixing (NAM) into a single waveform, the white and black levels of which are alternately selected by a synchronously

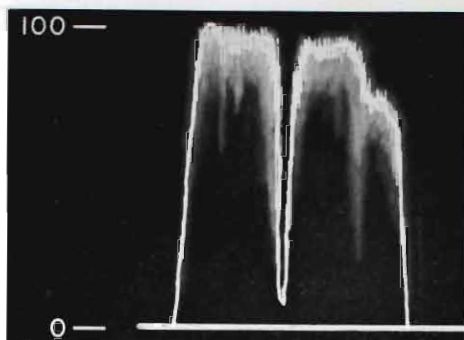

FIG. 7. Waveform monitor display of monochrome signal.

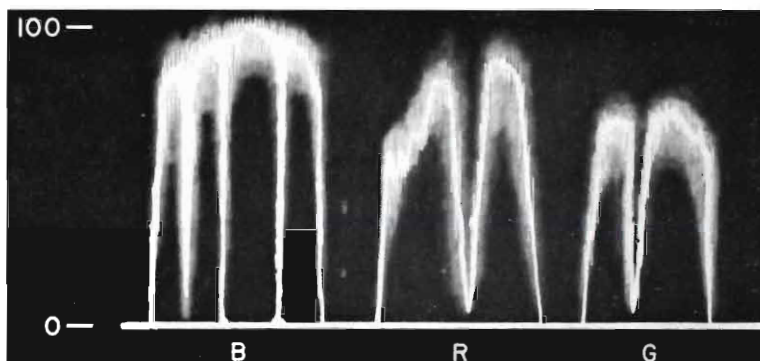

FIG. 8. Waveform monitor display of signals from three-tube color camera.

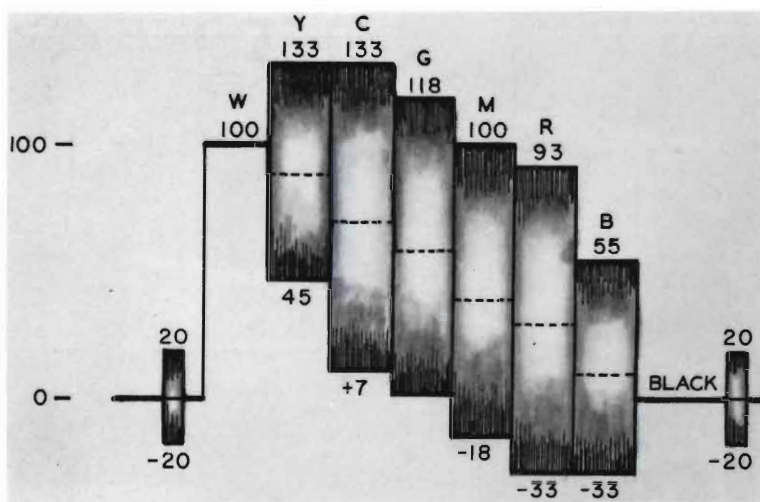

FIG. 9. Waveform monitor display of encoded output signal from three-tube color camera scanning a saturated color bar pattern.

operated electronic switch for display on the waveform monitor.

The method takes advantage of the fact that the peak amplitude height (100 per cent) and the base position (zero level) are primary considerations in level monitoring. Though the color film operator observes only a single waveform, as in monochrome, he is in effect monitoring the peaks of the three derived B_r , R_r , G_r signals. He also observes and maintains zero black level in the composite waveform as represented by the lowest amplitude of the three derived signals.

Non-additive-mixing of waveforms results in a waveform that at any instant of time represents the greatest amplitude of any of the waveshapes. This is illustrated in Fig. 13. In selecting the white and black levels, the electronic switch commutates continuously between the two NAM signals, taking two lines of NAM white and two lines of NAM black. When the output of the synchronous switch is applied to a waveform monitor, sweeping it one-half horizontal rate, the effect as seen on a waveform monitor is a superposition of the two signals.

NAM was developed to add color and monochrome in *one* presentation for accurate control of picture brightness and retention of color quality. As provided only in the TK-27, it eliminates any possibility of transmitter overload by improper adjustments, and prevents any undesirable effects at the receiver from these causes.

Automatic White and Black Level Controls

Density changes in slides and motion picture film cause light input variations to the pickup tubes in a color system, making it desirable to provide automatic means for controlling all four (R , G , B , M) channels proportionately and simultaneously as a function of the highest amplitude of any of the four channels. To control the channels independently of each other would completely destroy the colorimetry of the pictures.

The NAM white signal used in waveform monitoring as previously described is the correct signal to use in a loop for automatic white level (AWL) control. This signal is peak detected to give a DC voltage proportional to the peak amplitude of the AWL signal. Circuitry is seen in Fig. 12. The DC voltage is used to control simultaneously the gain of all the channels until the highest peak amplitude in the receiver-

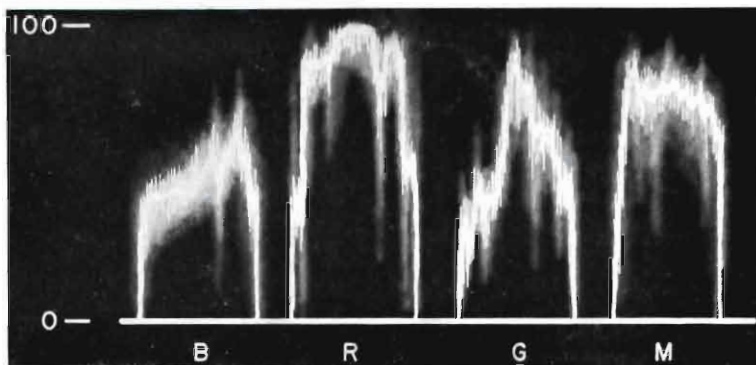

FIG. 10. Waveform monitor display of signals from a four-tube color camera.

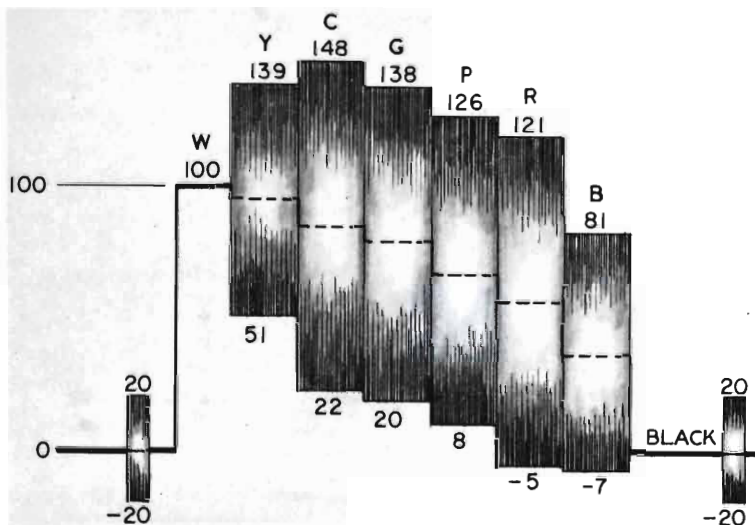

FIG. 11. Waveform monitor display of encoded output signal from a four-tube color camera scanning a saturated color bar pattern.

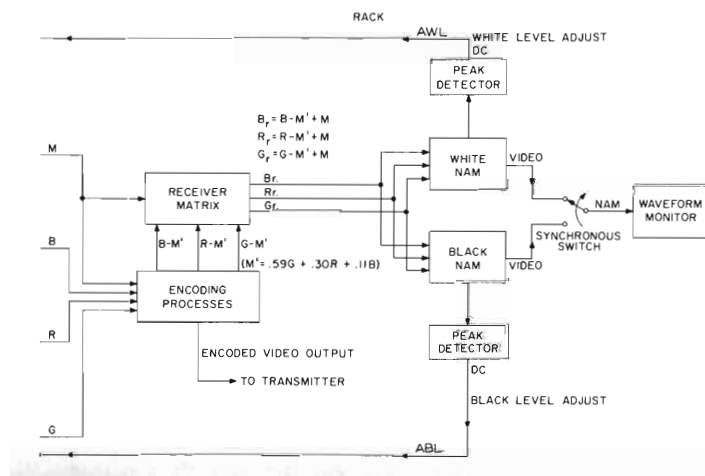

FIG. 12. Simplified block diagram of TK-27 monitoring and automatic systems.

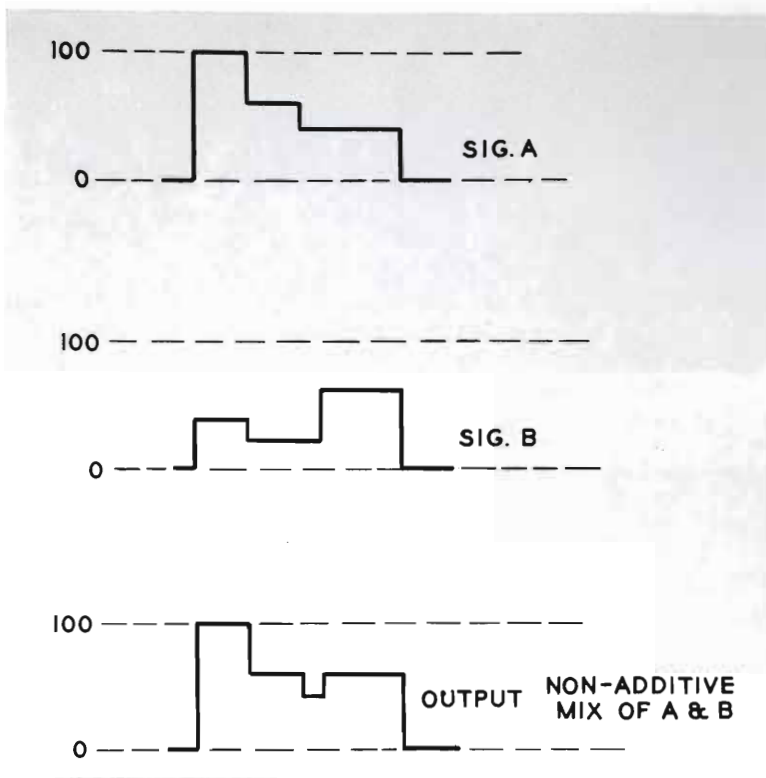

FIG. 13. Non-additive mixing of two signals, A and B, produces an output signal having only the highest amplitudes of either A or B.

matrixed signals is brought to the 100 per cent level. The TK-27 AWL circuit maintains constant output signals for input signal variations ranging to ± 6 db.

Automatic black level (ABL) control is accomplished in much the same manner as AWL. However, in this case, the output of the NAM black signal for waveform monitoring is used in conjunction with a peak detector to give a DC voltage to control black level proportionately in each of the four channels. For establishing ABL, the lowest amplitude point in the B_r , R_r , G_r receiver matrixed signals are brought down to zero level. Because of the way in which black level control is implemented in each of the channels, the gain of each channel is changed in direct proportion to the amount of black level shift. Thus, a balance for white level is always maintained between channels.

Automatic Sensitivity Control

For monochrome operation, the TK-27 color film camera employs an advanced form of automatic sensitivity control to

compensate for film-to-film variations in highlight brightness which in some cases can be expected to go as high as 30:1. It is achieved by varying electrode voltages on the luminance vidicon in accordance with a sensing signal while maintaining a fixed target voltage. This combination of AWL, ABL and ASC provides a degree of automatic operation previously found only in the TK-22.

Optical Black

It is characteristic of all vidicons used as color pickup tubes for the dark current (signal current from the tube when no light is on the face) to change as a function of temperature and target voltage. Since the dark currents vary independently for each tube, a change in the critical *black balance* of the color picture results if no corrective measures are taken. To avoid this in the TK-27, a portion of the picture picked up by the vidicons is made black by opaquing the corners of the image. This is not visible in the receiver because the raster extends beyond the picture tube frame. By use of keying circuits, the

TK-27 samples the masked areas, generates a correction voltage in each channel to correct black level and thus maintains proper black level balance.

"Monochrome Only" Operation

TK-27 control circuitry permits push-button selection of monochrome-only operation of the color film camera. With this mode, operation is identical to that of the TK-22 monochrome film camera. Only those circuits required for processing the signal from the $1\frac{1}{2}$ -inch luminance vidicon are used. Chrominance vidicons may be turned off for extended periods of monochrome operation.

Simplified Distribution System

A feature "extra" of the TK-27 is the use of internal drive signals. Formerly, color film cameras obtained the horizontal drive and vertical drive signals from the master synchronizing generator. Now these two signals are originated in the film camera (and studio cameras). This simplifies cabling, removes high voltage from the camera cable and results in a minimum number of distribution amplifiers.

Automatic Delay Compensation

The TK-27 utilizes an automatic sensing circuit used in all RCA color and monochrome cameras to detect time delay in the camera cable and automatically advance an internally generated horizontal drive signal to eliminate the delay in the outgoing video signal. Sensing or sampling of signal information is done at exactly the same point for color as for monochrome compensation, which is the final stage in the system prior to feeding the signal to the transmitter. This, in the case of color, compensates also for any delay occasioned by the encoder. Timing of the output signal is with respect to the incoming sync signal. There is no longer any need to provide separate distribution systems with delay lines in order to get timing for monochrome and color signals.

Ease of Test, Setup and Maintenance

Easier and more reliable test, setup and maintenance is provided by built in signal level test circuits. Internal test pulses speed up camera signal adjustments. These pulses determine that the pickup tube and amplifiers are operating at proper levels. Camera circuits are now arranged so that one man instead of two can set up and adjust the camera using these pulse techniques. By simply depressing a switch on the control panel, test pulses may be inserted into the system at any time for a check of stability.

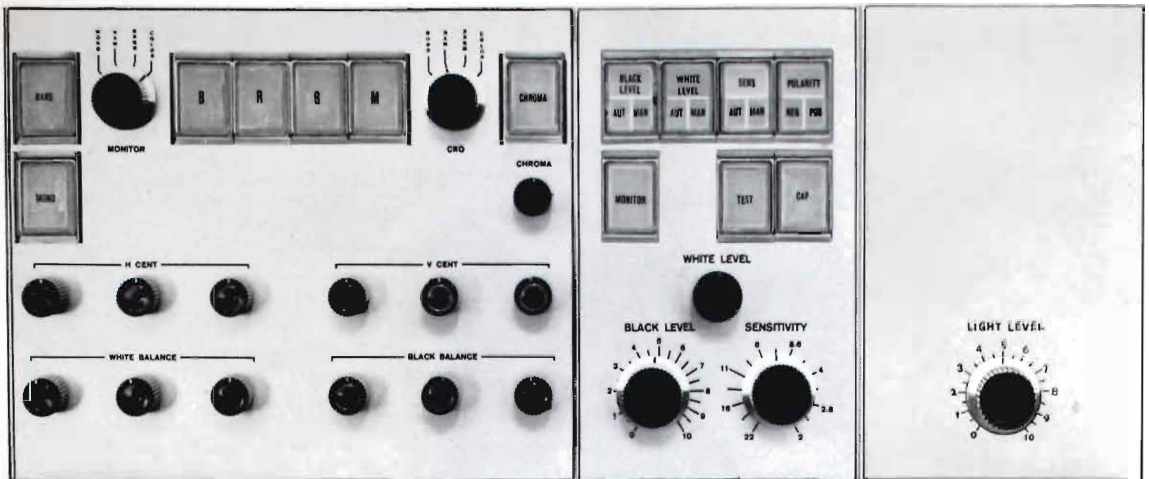

FIG. 14. TK-27 Control panels for operation of camera from control console or other location.

COLOR CONTROLS

BARS switch connects color bar signals to encoder.

MONITOR switch selects display seen on monitor—color output, mono output, NAM, BRGM.

B, R, G & M switches select outputs seen on monitor or CRO in BRGM position of monitor and CRO switches.

CRO switch selects display seen on CRO—same choice as on monitor switch.

CHROMA control varies white level in all color channels simultaneously but not monochrome white level.

MONO switch disables color channels and provides monochrome signal on all video outputs.

CHROMA switch turns chroma, but not burst off.

H CENT vernier controls for horizontal centering.

V CENT vernier controls for vertical centering.

WHITE BALANCE controls vary white level of color channels individually.

BLACK BALANCE controls vary black level of color channels individually.

MONOCHROME CONTROLS

BLACK LEVEL switch selects manual or automatic black level control.

WHITE LEVEL switch selects manual or automatic white level control.

SENSITIVITY switch selects manual or automatic sensitivity control.

POLARITY switch selects operation for positive or negative film.

MONITOR switch can be used with studio switcher to connect camera chain output to console monitor.

TEST switch energizes test pulses.

CAP switch caps the vidicon pickup tubes.

WHITE LEVEL directly controls white level when white level switch is in manual, or sets level to which peak white level is held when switch is in automatic.

BLACK LEVEL directly controls black level when black level switch is in manual, or sets level to which peak black level is held when switch is in automatic.

SENSITIVITY control when the sensitivity switch is set for manual, directly controls vidicon sensitivity. When switch is in automatic, this control sets level to which peak sensitivity is held.

(Right Panel)

LIGHT LEVEL controls neutral density disc for color operation.

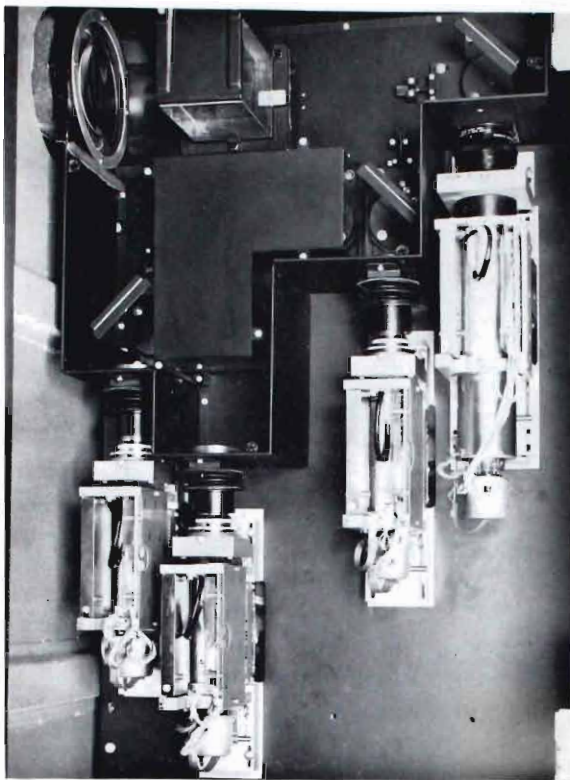

FIG. 15. TK-27 optical system and four vidicon assemblies. Light enters camera head through field lens at upper left and is split by prism into monochrome and color paths as illustrated in Fig. 16.

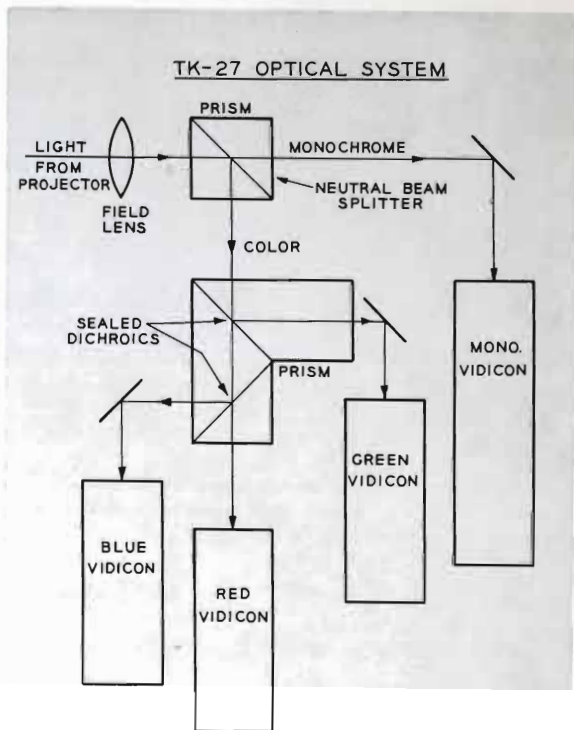

FIG. 16. Diagram showing TK-27 optical system and light paths.

Non-Interacting Controls

Two sets of controls on the color control panel. White Balance and Black Balance, are used to compensate for deficiencies in color film. They control to a limited degree (± 10 per cent) the amplitudes of the red, green and blue video signals. They are unique in that the white balance can be adjusted without affecting black balance, and black balance can be corrected without affecting white balance.

Chroma level may also be controlled and adjusted from the color film camera control panel. Thus, chroma deficiencies in color film can be compensated and adequate chroma levels maintained. This is possible because of the special NAM monitoring display provided in the TK-27 as previously described. Without looking at the blue, red and green signals (B_r , R_r , G_r) as the receiver sees them, and as provided by NAM, it would be extremely undesirable to provide chroma control because of the possibility of overloading the system. With the TK-27, however, it is

always possible to ascertain when maximum chroma levels have been reached.

Optical Advances

Assuring long term color life and freedom from secondary reflections the optical system of the TK-27 employs a *sealed* dichroic prism. Lenses and other optics for the TK-27 are also of a special design (see Figs. 15 and 16) which achieves unprecedented accuracy in superimposing electrically the four images from the vidicons on the face of the kinescope.

All optical alignment and registration adjustments are performed at the factory prior to shipment. Of course, standard electrical adjustments such as centering, size and skew must be made by the user, just as in any other camera.

Mechanical Design Features

Major efforts in mechanical design were directed toward increasing the rigidity and stability, and reducing the floor space required. As to the latter, a space saving of

two to one was achieved over the earlier TK-26 color film equipment.

Camera and optical assemblies are mounted on a $\frac{1}{2}$ -inch-thick, aluminum baseplate. This is rigidly fastened vertically to the structurally reinforced cabinet which is in turn bolted securely to the floor. Screw adjustments provide for alignment of the optical axis with the optical center line of the multiplexer/projector combination.

Plug-in design permits quick and easy removal of vidicon camera assemblies to facilitate trouble shooting, tube changing or replacement of tube yoke assemblies.

CCIR Operation

The TK-27 is equipped so that with appropriate CCIR drive signals it will produce NTSC type encoded signals with 50-cycle field and 625-line rates, and a 4.43 mc color subcarrier. Since relay control is provided in the appropriate modules, the camera chain can be transferred to this service by actuating a switch. I and Q bandwidths are the same as those used in domestic FCC approved transmissions.

Conclusions

The TK-27 is the second film camera to employ the transistorized module concept of equipment design. It gives better stability, reliability and picture quality than present tube equipments. It is a major step forward in reducing the broadcasters overall space requirement and providing simplified and economical color film operations.

Acknowledgement

The TK-27 color film camera design program was materially aided by the following engineering personnel: *Systems*, R. A. Dischert; *electrical*, A. Reisz, R. R. Brooks, L. J. Bazin and W. J. Derenbecher; *mechanical*, W. A. Tsien and J. P. Stewart; and *optical*, Miss G. L. Allee and L. T. Sachtleben.

FIG. 17. Author, Dave Taylor, shows 1½-inch vidicon used for luminance channel in TK-27 Color Film Camera.



FIG. 18. Vidicon pickup tubes, 1½-inch monochrome type and three 1-inch color types, are all electrostatically focused, greatly reducing amount of heat usually dissipated in camera head.



CONSIDERATIONS IN THE SELECTION OF A UHF TELEVISION ANTENNA

A Discussion of the Factors Involved
in Selecting the UHF-TV Antenna System
Best Suited for Coverage of the Market Area

by HERMAN E. GIHRING
Broadcast Antenna Engineering

Good coverage of a UHF-TV market depends to a great extent on the type of antenna system used and its relative location to the market served. The material that follows suggests criteria for the selection of an appropriate antenna in combination with available transmitter power.

Some of the questions that should be considered in analysis of a given coverage situation are listed below in Table I. The first five of these eight can be answered through visual observation. With this knowledge, a determination must be made of the five factors listed in Table II, below.

Antenna Power Gain

Antenna gain is a function of beam width, the narrower the beam, the greater the power gain. The relationship between power gain and beam-width (at the half-power point, or 0.707 voltage point) is: Beam width (in degrees) is approximately equal to 60 divided by the power gain.

Thus, an antenna with a power gain of 60 has a beam width of one degree; a power gain of 30, two degrees, and so on. This relationship applies, primarily, to a uniformly illuminated antenna. However, it is generally useful as a rule-of-thumb.

Fig. 1 graphically illustrates how a high-gain and a mid-gain antenna compare in coverage of given area if the same input power is used. The amplitudes of the two curves are adjusted to the square root of the ratio of the two power gains since the amplitude is expressed in relative voltage. Assuming that the main beam is directed toward the horizon ($1\frac{1}{2}$ -degree beam tilt), the high-gain antenna provides an increased field intensity of 3.2 db towards the horizon. However, it provides 4 db less field intensity 2 to 4 degrees below the horizon (a distance of 5.5 and 2.7 miles for a 1000-foot antenna elevation).

As a general rule, field strength should never be decreased when one antenna is

substituted for another, even if field strengths are at "city-grade" level or higher since receiving installations usually are just barely good enough to receive an established signal. The same rule applies with respect to a competitive signal. In general, higher-gain antennas should be used only with higher-power transmitters.

For rough terrain it is usually advisable to concentrate extremely high field strengths in the primary service area to obtain adequate signal strength behind hills. This is best done with a medium-gain antenna and high-transmitter power to maintain the same ERP. In order to assure adequate field strength behind a hill, where a large reduction can occur, a signal above normal requirements should be provided at the top of the hill. (A calculation such as given in the NAB Handbook in Section 2.1c should be made and an appropriate field strength provided at the top of the hill to overcome the loss encountered.)

TABLE I—Questions to be Considered

1. What is the geographic area to be covered in terms of square miles?
2. What is the field strength of established stations in the market?
3. How high above average terrain are antennas of established stations?
4. In which direction are most of the home-receiver antennas oriented?
5. Is the terrain within the coverage area flat or hilly?
6. Should an omnidirectional or directional antenna be used?
7. Is a multiple-antenna installation with other stations feasible?
8. Can an existing tower be used to good advantage?

TABLE II—Determinations to be Made

1. The gain of the antenna ideally suited to the market.
2. Antenna height above service area.
3. The necessary ERP for good coverage of the market.
4. Is beam-tilt necessary and, if so, how much?
5. The type of vertical pattern best suited to the situation (filled, shaped, etc.).

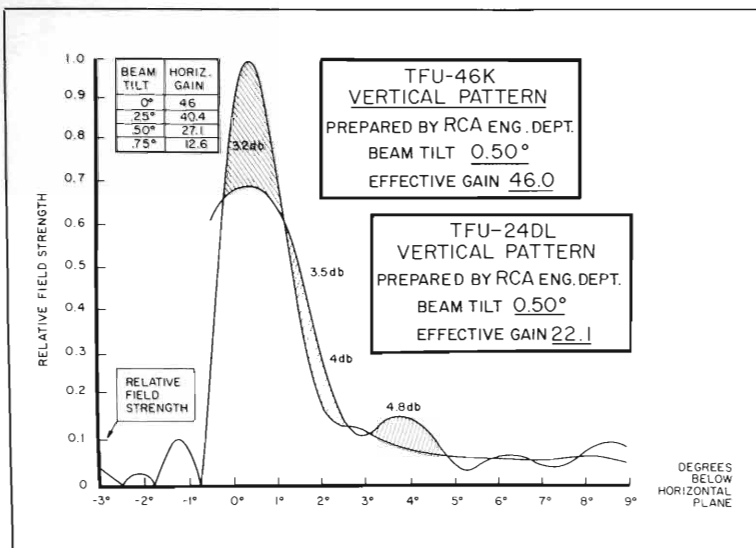

FIG. 1. Comparison of the field-strength curves between a 46- and a 24-gain antenna under identical circumstances. The shaded area shows the regions of increase or decrease in field strength when one antenna is substituted directly for the other.

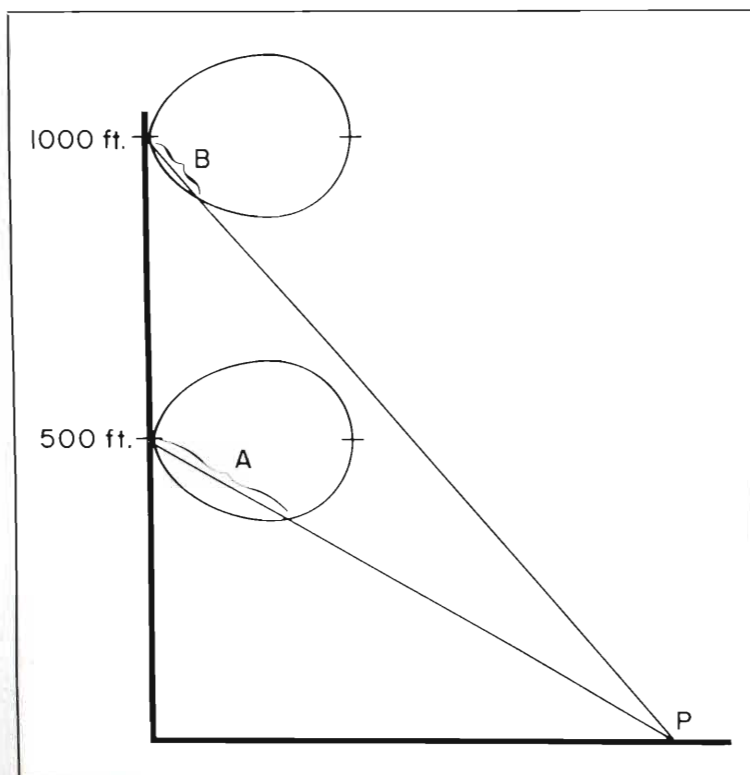

FIG. 2. Intercepts "A" and "B" show the loss in field strength at point "P" when the same antenna is raised from an elevation of 500 feet to one at 1000 feet.

Antenna Height

Is an increase in antenna height always desirable? Yes, when only the signal at the horizon is considered. However, the effect on the close-in coverage can be quite detrimental as shown in Fig. 2. Notice that the intercept *B* on the vertical pattern is much smaller than the intercept *A* for a lower antenna height when the field strength at point *P* is considered. Curves 3 and 4 of Fig. 10 indicate the reduction in field strength which occurs. Thus, an increase in antenna height should be accompanied by an increase in transmitter power to maintain existing field strength if the same antenna is used at the higher elevation. If a higher gain antenna only is used simultaneously with an increase in height, a loss of signal strength as much as 10 db could occur in the first few miles. Here, again, the loss can be offset by an increase in transmitter power.

Effective Radiated Power

Antennas capable of radiating 5 megawatts of ERP are already available and 50- and 150-kw transmitters soon will be. The desirability of using high transmitter power with high-gain antennas was pointed out earlier.

Beam Tilt

Table III indicates the angle to the "radio" horizon for various antenna heights.

In using a high-gain antenna it is advisable to use a beam tilt which aims the main lobe at or below the "radio" horizon. Fig. 7 illustrates the increase in local (close-in) coverage as the beam tilt is increased. These curves are for a TFU-46K high-gain antenna radiating one megawatt ERP. Note that the difference in field strength at the horizon is quite small.

TABLE III
Angle of the "Radio" Horizon at Various Tower Elevations

Tower Elev.—feet	Angle to "Radio" Horizon—degree
400.....	0.304
500.....	0.343
600.....	0.375
700.....	0.405
800.....	0.435
900.....	0.452
1000.....	0.487
1200.....	0.530
1400.....	0.577
1600.....	0.620
1800.....	0.650
2000.....	0.683
5000.....	1.080

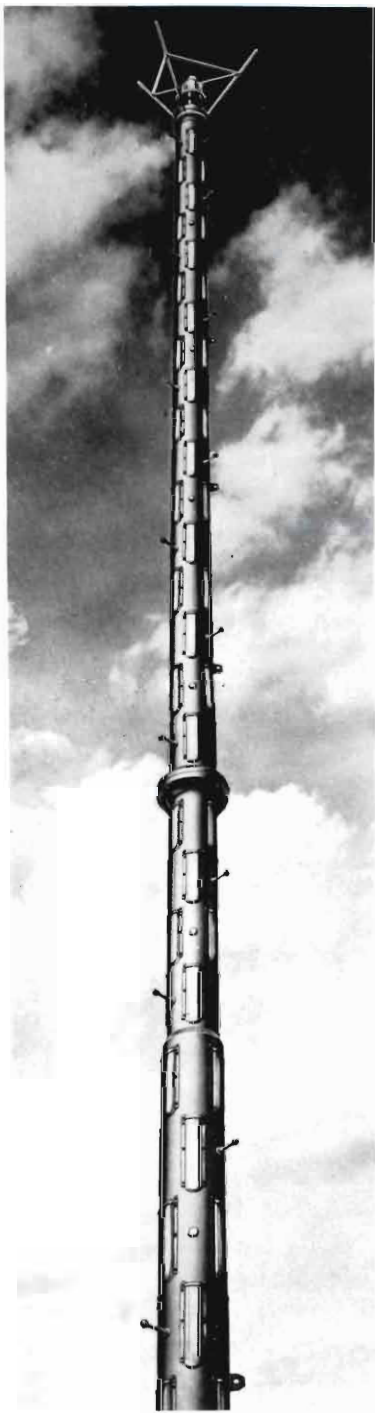

FIG. 3. The RCA TFU-46K UHF-Pylon antenna. This antenna is capable of 5,000,000 watts ERP with an input power of 110 kw. (Channels 14 to 55; 10:1 aural/visual power ratio.)

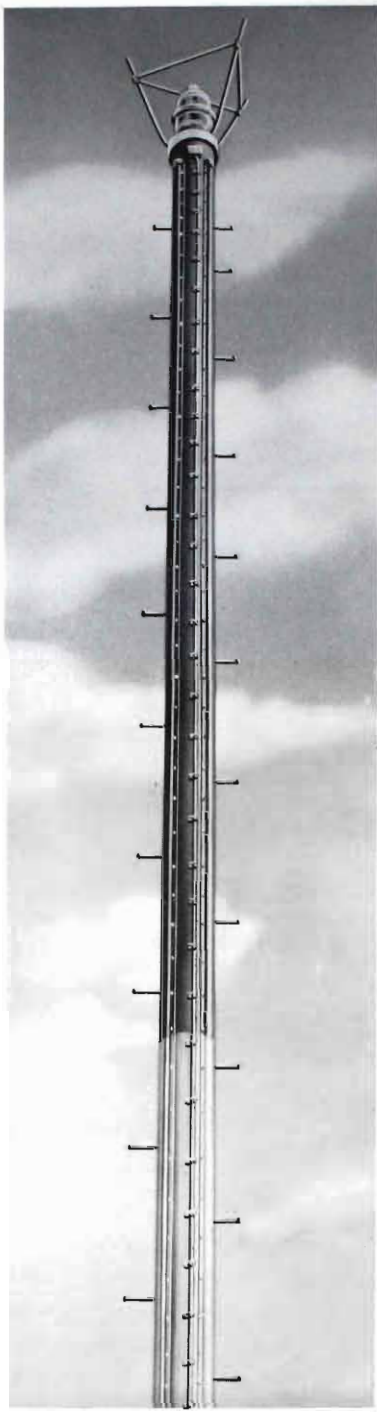

FIG. 4. The RCA TFU-30J UHF-Pylon Antenna. Offering a power gain of 30, this pylon is capable of 1.5 megawatts of ERP with a power input of 50 kw.

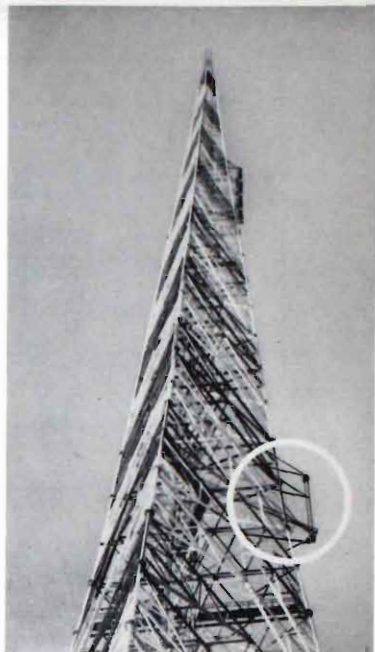

FIG. 5. Side-mounted UHF-Pylon antenna at WMVS, Milwaukee illustrates the technique of adding a UHF antenna to an existing tower—possibly a VHF tower.

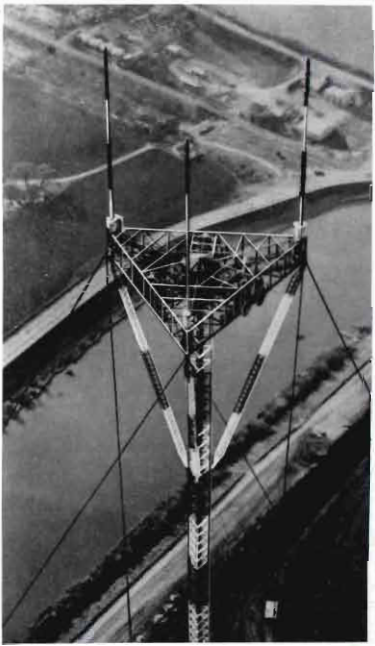

FIG. 6. This "California Candelabra" is typical of the candelabra-tower antennas now operating in Maryland, Texas and California. UHF antennas require far less spacing than do VHF.

The horizontal gain of this antenna for typical beam tilts are shown in Table IV.

TABLE IV

Power Gain and Beam Tilt: TFU-46K

Beam Tilt	Horizontal Power Gain
0.0	46.0
0.25	40.4
0.50	27.1
0.75	12.6

The rapid decrease in this gain figure may, at times, deter the use of beam tilt. However, coverage is most effective when the main beam of the antenna is directed toward the horizon or slightly below. Both the main-beam vertical gain and the horizontal gain can be filed in the license application.

Vertical Pattern

There are, broadly speaking, three types of vertical patterns namely:

1. *sin x/x*
2. *filled*
3. *shaped*.

A *sin x/x* pattern for a vertical power gain of 38 is shown in Fig. 8. Note that the nulls (points of low field strength) go to a minimum beginning at 7.4 miles (1.5

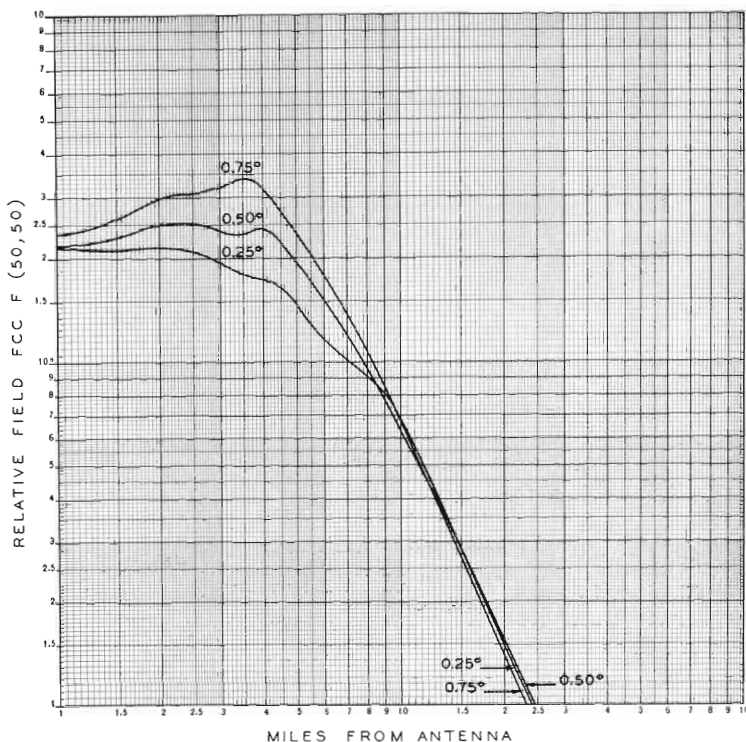
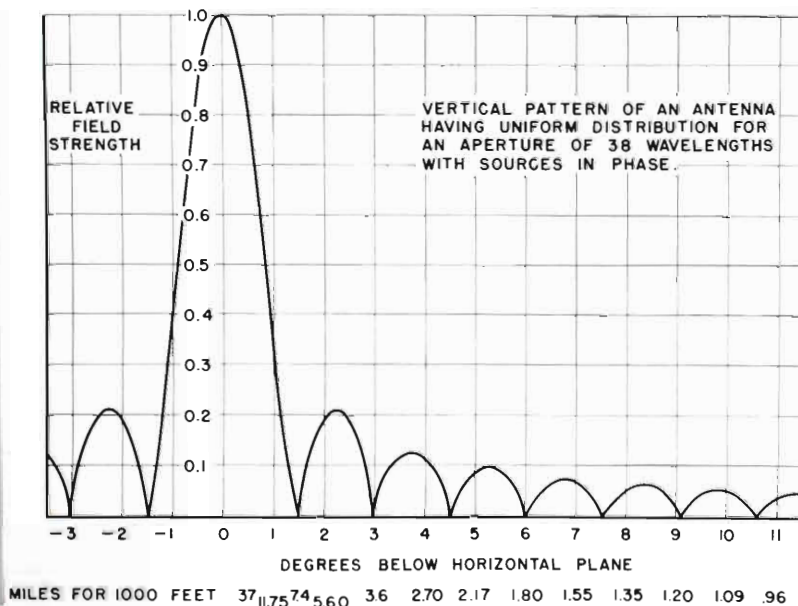

FIG. 7. Comparison of local field-strength increase with beam tilt aimed at horizon or slightly below. The loss in distant coverage is relatively small.

FIG. 8. Vertical pattern of an antenna with a gain of 38 that uses a "sin x/x" pattern with uniform illumination.



degrees below horizontal plane) for a 1000-foot antenna elevation. Beyond that point, the zero nulls occur at $\frac{1}{2}$, $\frac{1}{3}$, $\frac{1}{4}$, etc. of the distance. As a result, the $\sin x/x$ pattern is, generally, not used.

A filled pattern with an antenna gain of 27 is shown in Fig. 9. This null-fill is accomplished by adjustment of the amplitude and the phase of the current in each of the radiating elements. An amplitude step near the center of the antenna fills the odd-numbered nulls (first, third, fifth, etc.). Some phase adjustment is required to fill in the even-numbered nulls.

Filled-pattern antennas render excellent service in many parts of the country. Most of the UHF-broadcast antennas now in use are of the filled-pattern type.

A shaped TFU-46K pattern is shown in Fig. 1. The amplitude and phase of each antenna layer is computed to produce this pattern which results in more-uniform field strength.

The effect of the above factor is summarized in Fig. 10 and Table V. A study of these curves reveals the effect of gain, height, ERP, and type of vertical pattern. Choosing these parameters carefully allows

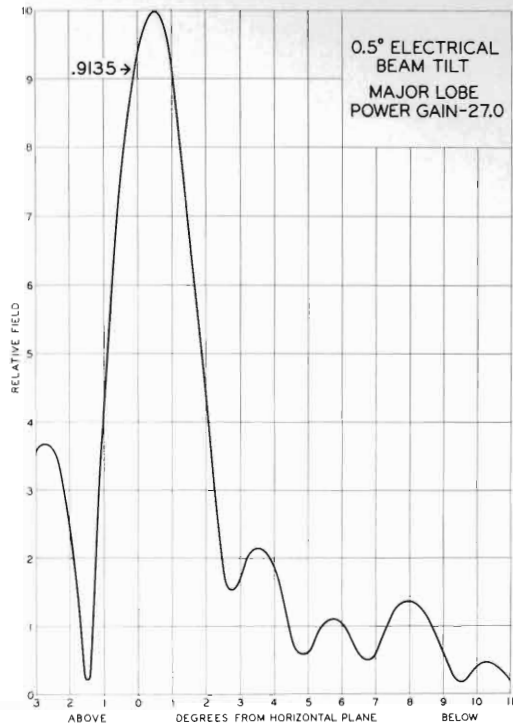

FIG. 9. Vertical field-strength curve of a "filled" pattern antenna produced by variation in amplitude and phase of the energy at each layer.

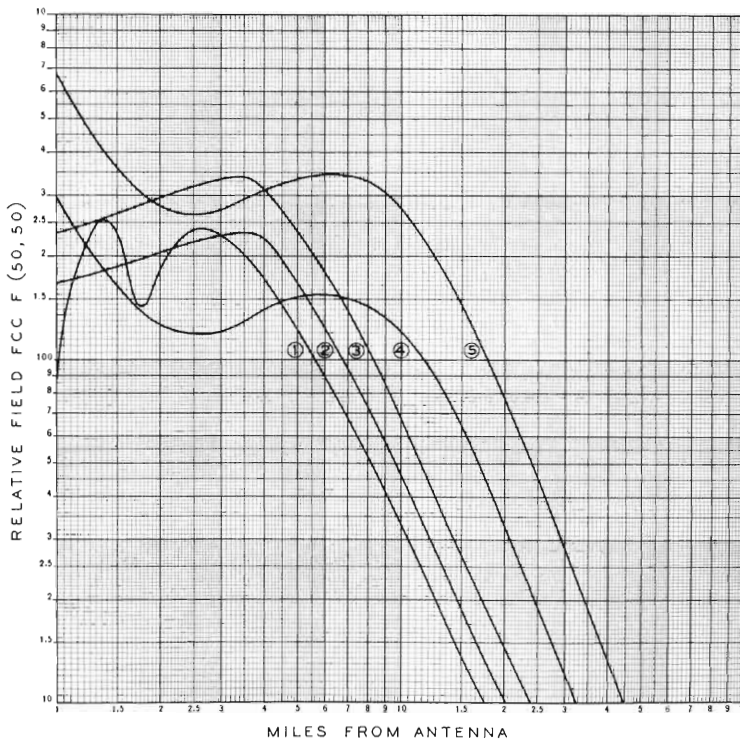

FIG. 10. Comparison of the effect of gain, antenna elevation and ERP on field strength based on the FCC F(50,50) curves and are not applicable to any given situation since terrain can influence values as much as 20 db or more. (See statement concerning the application of the curves in the FCC's Sixth Order and Report, par. 3.383). The curves are used for comparative purposes only so as to point out certain facts which aid in selecting the best combination of parameters for operation under certain conditions.

TABLE V

Curve No.	Antenna	Gain	Beam Tilt	Elev.	ERP Kw
1	TFU-24DL	20.5	0.75	500	225
2	TFU-46K	46	0.75	500	500
3	TFU-46K	46	0.75	500	1000
4	TFU-46K	46	0.75	1000	1000
5	TFU-46K	46	0.75	1000	5000

Curves 1 and 2 show the relative fields when a TFU-46K replaces a TFU-24DL with the same 12.5 kw transmitter with no change in antenna elevation.

Curve 3 shows the relative field strength of the same antenna with an increase in transmitter power to 25 kw. Curve 4 shows the relative field strength of the same antenna with an increase in height to 1000 feet.

Curve 5 shows the relative field strength with the same conditions as curve 4 except with an ERP of 5,000 kw.

Based on these curves, a few general observations can be made:

1. For local coverage, a combination such as that in curve 1 can be used.
2. The service area can be increased by increasing antenna gain, increasing transmitter power or increasing antenna height.
3. When increasing antenna gain, the effect of the gain increase on local coverage should be studied; if local field strength is reduced, an increase in transmitter power is necessary.
4. When increasing antenna height, particularly when the antenna is a high-gain device, transmitter power must be increased.

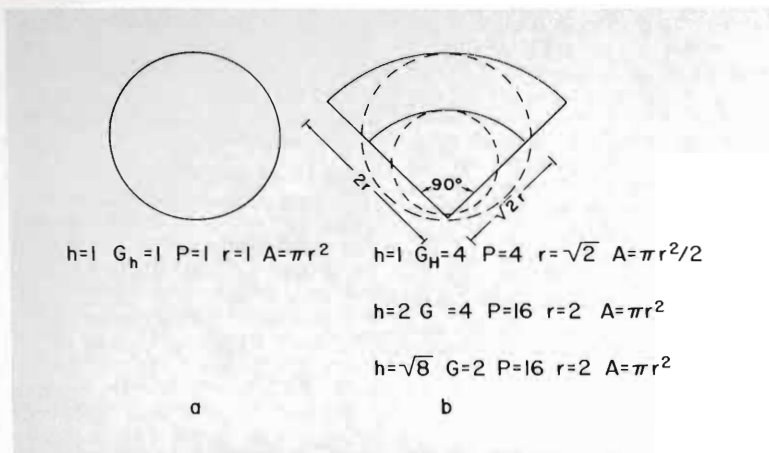

FIG. 11. The most efficient coverage is realized when the antenna location is central to the area; only half of the service area is covered with the same ERP at the same height with the location of a directional antenna at the perimeter of the service area (see text).

considerable flexibility in serving the requirements of a given area in an optimum manner.

Directional UHF Antennas

Directional antennas have a number of useful applications. They have been used successfully to cover special situations such as the San Joaquin Valley in California and also to cover service areas adjacent to large bodies of water. There are situations, however, when their use is questionable from a viewpoint of coverage efficiency. Coverage efficiency can be defined as covering a given area with a given field intensity with a minimum amount of effective radiated power. Height is also a factor as will be shown below. Some relative approximate relationships can be deduced from propagation formulas which pertain within the radio horizon over plane earth as follows:

$$r \propto \sqrt[4]{P}$$

$$A \propto \sqrt{P}$$

$$P \propto h^2$$

Where r is the distance to a given field contour

P^* is the "effective radiated power" in the main beam

A is the area served within a given field contour

h is the height of the antenna above the service area in feet

* The value used here is not only the product of transmitter power and antenna gain but includes also the increase in "effective ERP" due to the increase in height since P is proportional to h^2 .

In Fig. 11a the area enclosed by a given field intensity contour for a relative "effective radiated power" of "1" and a relative height of "1" is πr^2 . If the antenna site were moved to the edge of the circle (instead of the center), a directional antenna (with a quarter-circle horizontal pattern) could be used as shown in Fig. 11b. Such an antenna offers a horizontal gain of four, thus, $P = 4$.

In the relationship above $r \propto \sqrt[4]{P}$, r becomes $\sqrt{2}$. The area to the same field intensity contour served is then

$$A = \frac{\pi (\sqrt{2}r)^2}{4} = \frac{\pi r^2}{2}$$

Using the same transmitter power with an optimum directional antenna with a horizontal gain of 4, only one half of the area $\left(\frac{\pi r^2}{2}\right)$ is covered as compared to that on Fig. 11a and as a result the coverage efficiency is 50 per cent.

Because of the fourth root relationship between distance and radiated power, the center of the area to be covered is the best location for maximum coverage efficiency.

However, another factor is antenna height. From the relationship

$$A = \frac{\pi (\sqrt{2}r)^2}{4}$$

it is noted that should antenna height be doubled, the "effective ERP" increases four times. Hence in Fig. 11b, doubling the height provides an "effective ERP" (P) of 16 and r becomes 2. The area covered is then

$$A = \frac{\pi (2r)^2}{4} = \pi r^2$$

which is the same as that for the area in Fig. 11a.

The antenna postulated in Fig. 11b however, is not permitted under the "15 db rule." A practical antenna may have a horizontal gain of about two. To realize an "effective ERP" of 16 will require an antenna height increase of $\sqrt{8}$ or, 2.8 times.

Hence, we get another general rule: Where sufficient natural height is available, a directional antenna can be used to advantage. To realize any advantage however, heights beyond a relative value of 2.8 must be obtained under the conditions set forth here.

Multiple Antenna Installations

Multiple-antenna installations are becoming more common. There is a trend in this direction for a number of reasons:

Commercial air routes around metropolitan centers restrict areas available for tall structures; second, the common location for all stations in a given market eliminates many of the problems of receiving antenna orientation; and, third, installation economies result, especially at UHF frequencies, because of shared expenses among the sharing stations.

There are a number of ways in which multiple installations take form:

1. Candelabra Tower (see Figs. 6 and 12)

Four VHF installations using candelabra towers are currently in daily operation. Candelabra towers are even more applicable for UHF television.

FIG. 12. UHF candelabra arrangements are most practical because of the possibility of short spacing between antennas. Spacings as short as 10 to 15 feet permit good circularity patterns for each antenna.

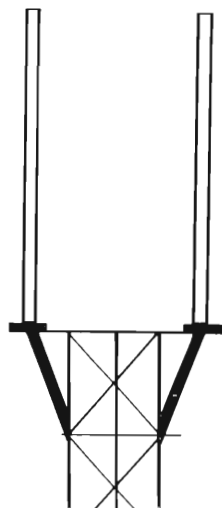

MULTICARTRIDGE TAPE PLAYBACK SYSTEM

New RT-8 Playback Unit Features Roll-Out Tape Transports,
Plug-in Transistor Circuit Boards and Facilities for Automatic Operation

by ROBERT A. REYNOLDS
Audio Products Merchandising

With the final approval of the National Association of Broadcasters', "Standard for Cartridge Tape Recording and Reproducing," the endless-loop tape cartridge had received official recognition by the broadcast industry.

The profound effects which this cartridge has had on the industry are certainly known to all. In a relatively few short years the cartridge not only gen-

erated a whole new concept in the handling of program material, but also fathered the development of a wide variety of cartridge tape recording and reproducing devices as well.

The immediate acceptance of this new tape system by broadcasters, and the extensive use of the single cartridge playback unit, clearly demonstrates the need for multiple cartridge reproducing devices.

Early Multicartridge Prototypes

Initial considerations for a multiple cartridge playback unit called for a device which could be conveniently installed at an operators position and provide a capacity of ten cartridges. This provided the operator with the capability of handling peak-load periods.

This approach to a multiple system was selected over the larger storage capacity

FIG. 1. Each RT-8 cartridge tape playback unit is comprised of four cartridge tape decks. Equipment can be used in multiples of 4, 8, 12, or more decks.



system, because it was felt that a smaller one, with unlimited cartridge accessibility, would have greater flexibility in a busy control room.

The multiple cartridge unit shown by RCA at the 1961 NAB Convention contained two stacked sets of five tape decks, with a single capstan shaft and motor for each set. The common capstan shaft design was subsequently abandoned in favor of individual motors and capstans for each tape deck. This change was brought about primarily because of the difficulty in servicing and adjusting the decks in the common capstan system.

Experience soon demonstrated that while a station's initial purchase of cartridge tape equipment usually included two single playback units, the same station would purchase one to three additional playback units, usually within a year's time. This indication led to reconsideration of the cartridge storage capacity required in a multiple system. The most logical number seemed to be four cartridges, and it is upon this number that the present design is based.

Today's Multicartridge Tape System

The RT-8 Multicartridge Tape System (See Fig. 1) is a tape cartridge reproducing device designed to meet NAB standards. It contains four independent roll-out tape transports, plug-in transistor circuit boards and control relays, a mode selector switch and separate start switches for each of the tape transports. The unit is housed in a rack mounting cabinet, measuring 17½ inches high, 19 inches wide, and 16¾ inches deep. It weighs 112 pounds with the four tape transports removed and 152 pounds total with all four installed. Adequate ventilation has been provided in the design of the chassis and cabinet, to allow two or more RT-8's to be stack mounted in a standard cabinet rack.

Tape Transport

Perhaps one of the most interesting and useful features of the multicartridge unit is the roll-out tape transport (See Fig. 2). Here in one compact arrangement is the mechanical heart of the system.

The drive system for the transport (See Fig. 3) consists of a heavy duty hysteresis synchronous motor, coupled by "O" ring belts to a precision ground capstan and flywheel assembly. This type of drive system allows the motor to be placed as far away as possible from the head assembly. This greatly reduces the possibility of hum being induced into the heads by the motor field.

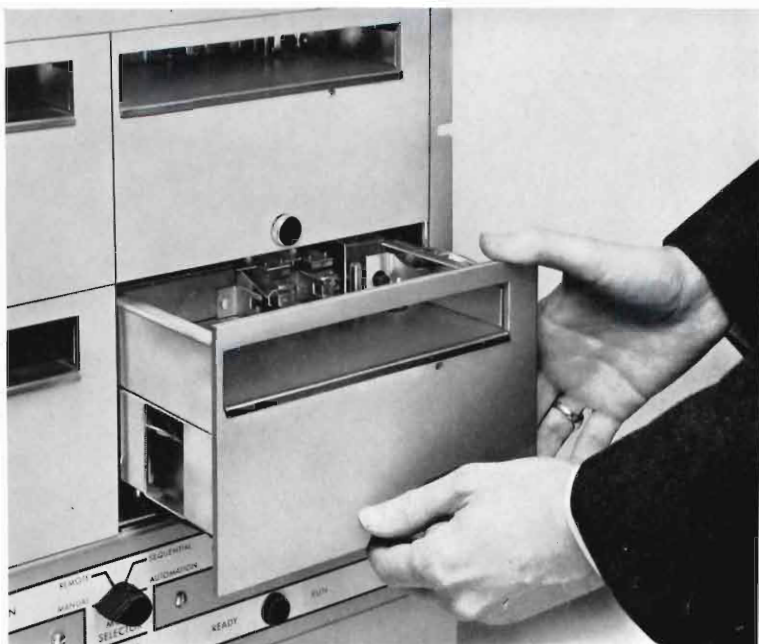
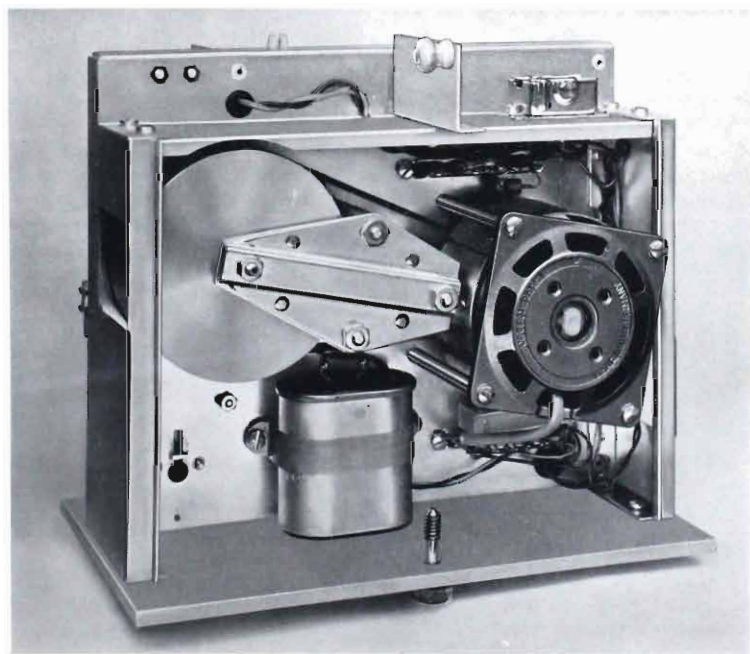

FIG. 2. Roll-out tape transports provide complete accessibility for routine maintenance of tape decks.

FIG. 3. The drive system for the transport includes a heavy-duty hysteresis synchronous motor and a precision ground capstan and flywheel assembly.



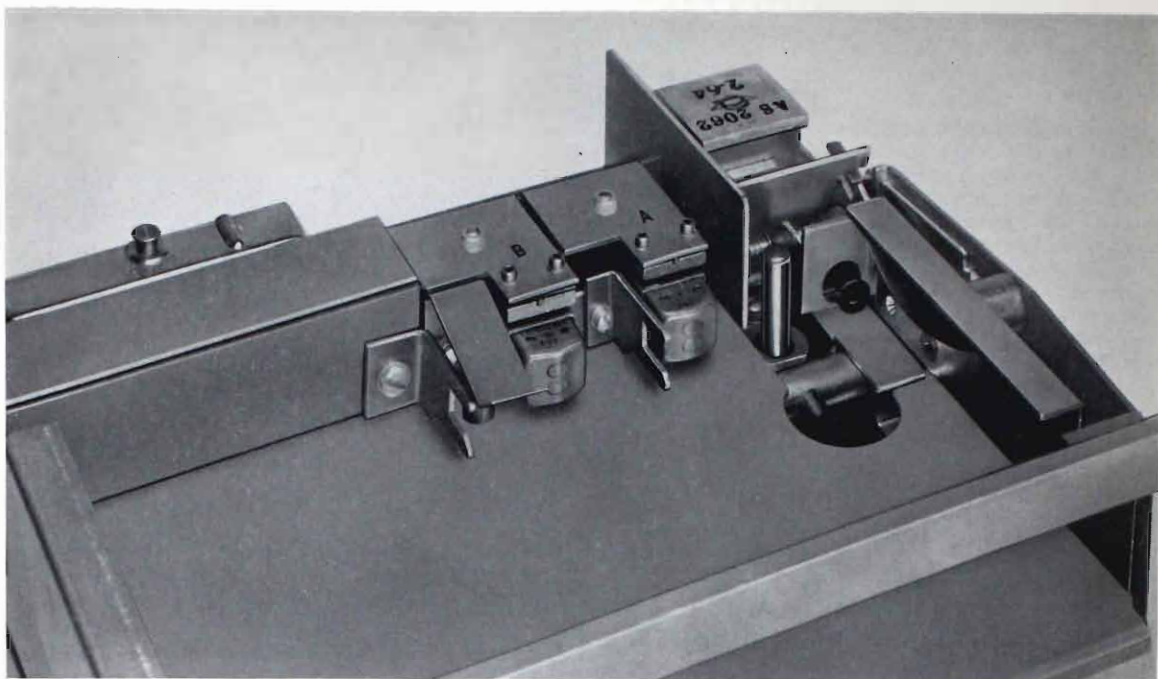

FIG. 4. Close-up of a single tape deck showing detail of the heads.

According to the new NAB standards, the tape speed is specified as $7\frac{1}{2}$ IPS with a speed accuracy of ± 0.4 per cent; machine tape pulling force is a minimum $1\frac{1}{2}$ pounds; flutter does not exceed 0.2 per cent RMS.

The head mounting bracket contains a pair of vernier, head azimuth adjusting screws, as well as a separate head height adjusting screw, for each of the two heads as shown in Fig. 4. (Note: Since the transport is used only for playback, the "B" head, or record head is not electrically used in the system. This is a dummy head used only to insure proper tape guidance within the cartridge.)

Elongated mounting holes in the bottom of the head bracket assembly allows adjustment of the heads for proper penetration into the tape cartridge.

As in all previous RCA tape cartridge mechanisms, insertion of a cartridge cocks the mechanical system by swinging the pressure roller up, to within a fraction of an inch of the capstan. This assures fast starts and quiet operation upon playback. Mechanical release of the cartridge is accomplished by merely lifting its edge before removing it from the slot in the transport.

A hold-down spring located to the left of the "B" head position insures proper alignment of the cartridge when it is inserted into the mechanism. The top plate of the transport, which supports the cartridge, is made of stainless steel, which helps considerably in maintaining a clean cartridge surface area.

The transport will accept either of the three NAB sizes of cartridge, with playback time varying from a few seconds to 31 minutes. It is identical to those used in the RCA Stereo RT-37 and Monaural RT-17 single cartridge playback units.

Power

The basic power requirements of the system are 115 or 230 volts 60 cycle. Through the use of an inexpensive kit, the unit may be converted to 50 cycle power operation. This ability to convert to 50 cycle power operation simply and inexpensively, is another plus feature of the belt drive system of the tape transports, since the only changes required are the motor capacitor and pulley.

Operation

As each cartridge is inserted into its respective transport slot, a "Ready" light

indicator, located on the control panel, is illuminated to indicate the preparedness of the cartridge for playback. See Fig. 5.

The mode switch selects one of the following four modes of operation.

1. Manual—This mode allows the operator to select the desired cartridge play sequence by operating any one of the four start buttons at random. The cartridge that is operating continues to run until it is automatically "cued-up." The next cartridge is started by again pushing the appropriate start button. When a remote control panel is used in the system, its operation is defeated by placing the switch in the manual position. Under these circumstances, only the local operator may control the unit.
2. Remote Control—This is basically the same as the manual position except that playback of the cartridge is controlled only from the remote location. This mode defeats operation of the local "start" buttons.
3. Sequential—In this mode, cartridges may be started from either the local or remote control positions. Once started, the end of message cue from the car-

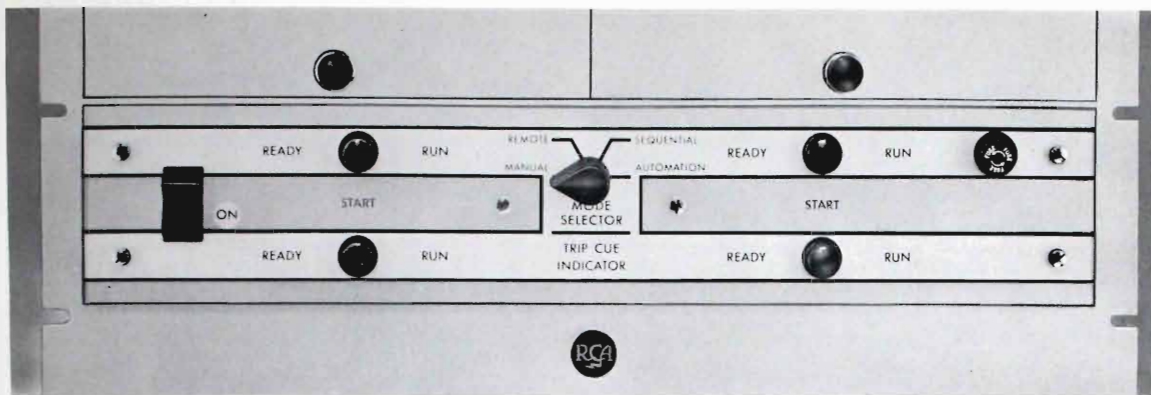

FIG. 5. Close-up of the mode selector switch and other operating indicators and controls.

tridge in operation starts the next cartridge in sequence. The sequence continues automatically within the system running through as many cartridges as have been inserted. Any cartridge may be used to start the sequence.

4. Automation—This mode permits external pulse from an automation system to activate individual cartridges as desired. End of message cues from the active cartridge starts the next device in the automation system. When the mode switch is in this position all manual control (local or remote) is removed.

Once a cartridge is started in the system, the "Ready" indicator is extinguished and the "Run" indicator is illuminated. The cartridge continues to run until it reaches its "cued-up" position, at which time it stops. At this time the "Run" indicator is extinguished and the "Ready" indicator is illuminated, informing the operator that the cartridge is again ready for playback. This sequence of "Ready" and "Run" indicators continues for each of the four cartridges regardless of which cartridge is playing back.

One additional indicator is provided on the control panel. It illuminates whenever a "Trip Cue" passes through the system. "Trip Cue" circuitry, while it is not supplied with the RT-8 unit, may be obtained as an optional accessory item.

The operating modes selected for the control panel are those most frequently used. This does not mean, however, that they are the only modes possible. Provisions have been made in the equipment to allow many other combinations of the built-in modes. These can be achieved by strap changes on the terminal strip.

Solid-State Electronics

Three basic plug-in circuit boards are used in the multicartridge system, the playback amplifier, power supply and cue amplifier. The playback and power supply boards are identical to the boards used in the RCA RT-37 and RT-17 single cartridge units. The cue amplifier board includes both the NAB standard 1000 cps cue amplifier and the NAB standard 150 cps end of message cue amplifier.

A single type silicon transistor is used exclusively throughout the program and cue tone amplifiers to minimize the number of spare transistors the user has to stock and to assure stable operation of the system. This transistor is the RCA 2N2270.

The performance characteristics of the silicon transistor are generally more de-

sirable than those of the germanium type and are considerably more stable with respect to temperature. Leakage currents are lower and variations in this value have less effect upon the circuit performance.

The playback amplifier and power supply boards are accessible at the bottom, rear of the housing as shown in Fig. 6. Provisions are included for the installation of two playback boards when the unit is used for stereo operation.

The four cue amplifier boards are also installed at the rear of the unit, directly behind their associated tape transport as shown in Fig. 7.

When "Random Trip Cue" is required in the RT-8 system for activation of a slide projector or other device during play of a cartridge, an accessory NAB standard 8 kc

FIG. 6. Playback amplifier and power supply circuit boards plug-in at the rear of the housing.

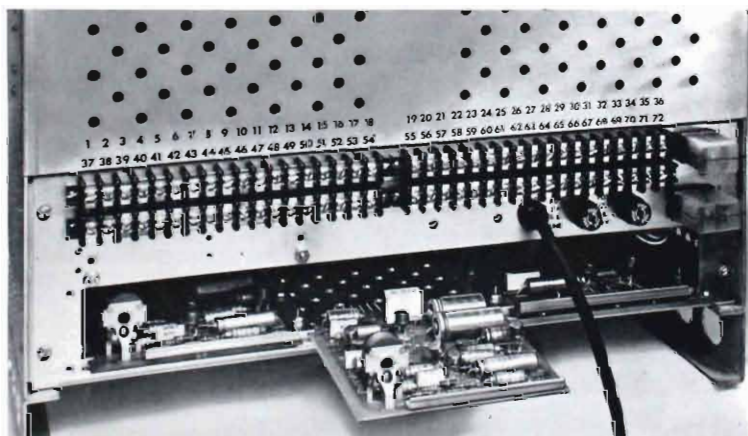

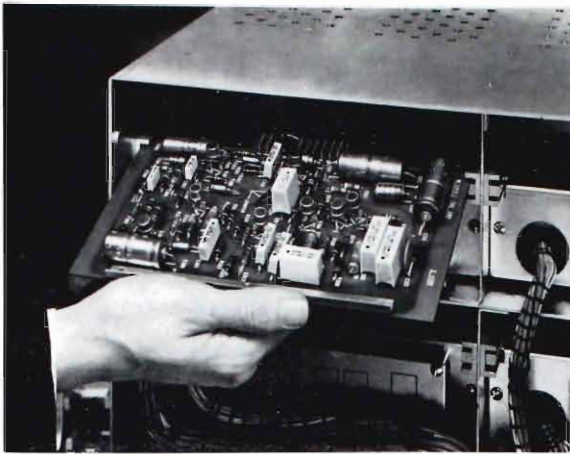

FIG. 7. Cue amplifier boards are also installed at the rear of the housing, directly behind their associated tape transport.

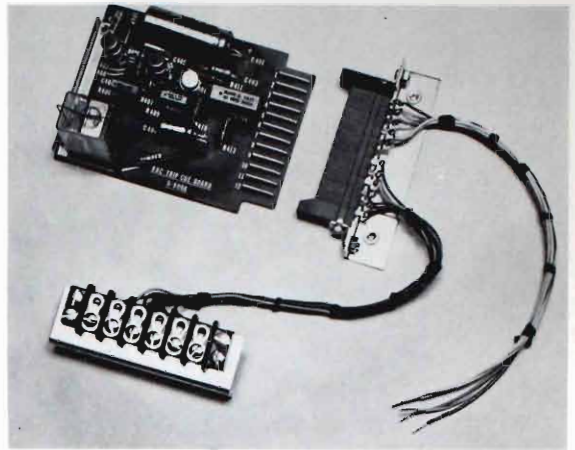

FIG. 8. An 8 KC "random trip cue board" can be installed as an accessory.

"Random Trip Cue" board may be installed (See Fig. 8). This board contains the 8 kc amplifier, its control relay and terminal board for external connections.

According to NAB standards the primary or stop cue is specified as 1000 cps \pm 75 cps; the secondary or end-of-message cue, as 150 cps \pm 30 cps; and the tertiary or auxiliary cue, as 8 KC \pm 1 KC. This auxiliary cue, is the RCA "Random Trip Cue." The cue burst duration has also been specified as 500 milliseconds \pm 250 milliseconds.

The electrical specifications for the RT-8 are essentially those of the RCA RT-17 and RT-37 single cartridge playback units, and meet all of the NAB standards for cartridge tape reproducing systems. The maximum output level from the playback amplifier is \pm 18 dbm. Two output transformers are included in the basic system, providing 600/150 ohm balanced audio outputs for either monaural or stereo operation.

External Connections

All external connections are made to a barrier type terminal strip on the rear apron of the chassis. Individual stop button controls have not been provided on the control panel since the RT-8 is intended for automatic cartridge playback and cueing. However, if such facilities are needed in a special application, circuitry and terminals are provided. It requires only one set of normally closed contacts for each of the four stop circuits and master stop circuit, provision for which is also included.

One normally open and one normally closed set of "End of Message Cue" relay contacts, for each of the four cartridge systems are also available on the terminal strip. These contacts can be used for various special applications. They are completely isolated from all other RT-8 circuitry.

Relay Functions

A set of six plug-in, relays, shown in Fig. 9, is associated with each individual transport system. These relays provide the ready, start, run, and play control functions of the transport as well as the cue and trip (end of message cue) functions.

The relays are located at the rear of each transport compartment and are protected from dirt and dust by individual plastic covers. As a further protection against relays becoming loose in their sockets during operation, an overall metal cover is fastened to the chassis to hold the relays rigidly in place.

A mute relay and an audio switch relay are the final two relays in the system. The mute relay mutes the audio output during the initial starting of the playback process and during the time in which the playback heads are switched to or from the playback amplifier. This prevents any noise which may be created during these functions from getting into the program circuits.

The audio switch relay provides automatic audio switching to a single program channel when two or more RT-8's are connected in tandem.

Basic System

The functional diagram, Fig. 10, shows the basic flow of audio and control in the RT-8. The four transport systems are identical to one another and are coupled together through control circuit interlocking, common mute buss, audio buss and random trip buss.

Assuming that the RT-8 is in the sequential operating mode and the first transport is in operation, the program audio from the head is routed through the control relay circuit to the input of the program amplifier, via the common audio buss. The output of the program amplifier is fed through the mute relay and audio switch relay. A non-switched audio output is available through the mute relay, or if tandem operation is in use, an output from the audio switch relay is available.

At the end of program material in the first cartridge, an end-of-message cue tone is transmitted from the head to the cue amplifier. The 150 cps tone is amplified and activates the appropriate relay in the first control circuit. A start pulse is then transmitted to the second control circuit, through the interlock circuits, and the playback process is repeated. Only the cartridge which is started can feed audio to the program amplifier. If there had not been a cartridge inserted in the second transport, the start pulse would have automatically been routed to the next transport.

The cartridge in the first transport continues to run until the 1000 cps cue tone is received by the cue amplifier, which in

turn activates its relay and stops the transport.

If the "Random Trip Cue" amplifier is used, the 8 kc cue tone is routed through the cue amplifier to the Random Trip Amplifier (via the common buss) which activates its relay and creates a pulse for external use.

Various Applications

As a single unit, the RT-8 (either mono-aural or stereo) can be used to replace four playback units with the added convenience of automatic sequencing when desired. Or, when used in multiples of 4, 8, 12 or more units, the RT-8 systems can provide enough cartridge storage capacity to give continuous programming over long time periods.

There are many special features and automatic facilities built into the RCA Multi-cartridge Tape System. The possibilities for its use are almost unlimited. The standard applications mentioned are but a few. Today's automation conscious broadcaster will undoubtedly find a great many more.

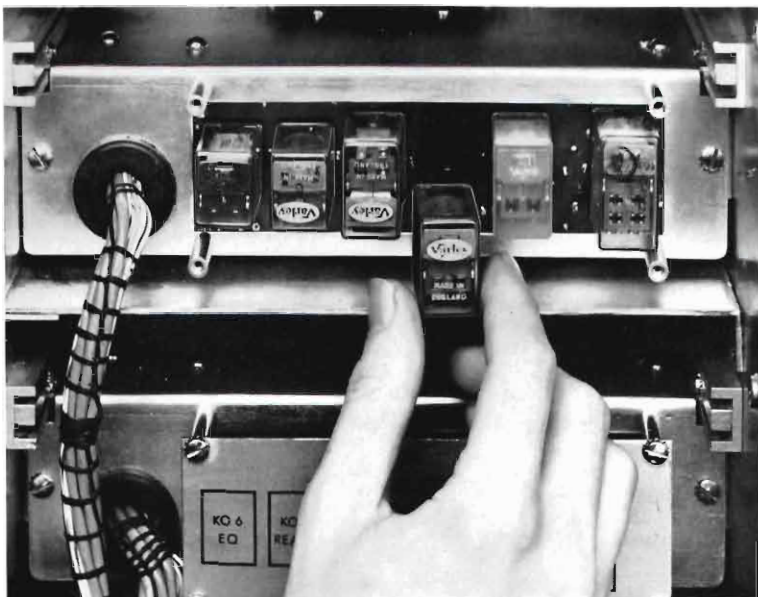
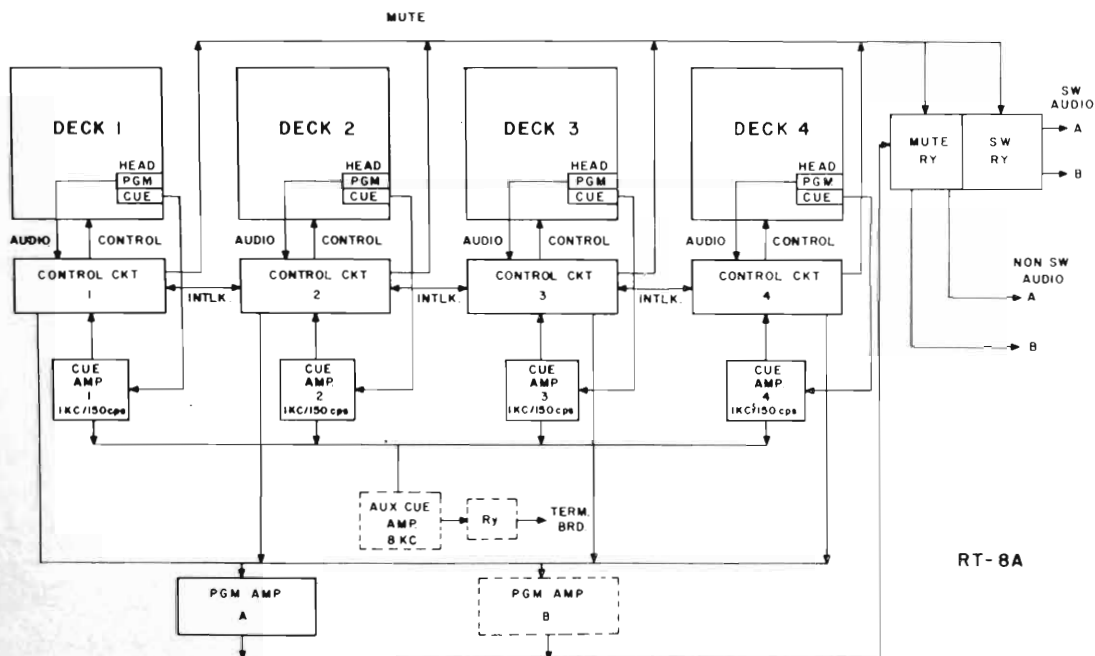

FIG. 9. A set of six plug-in relays is associated with each tape transport.

FIG. 10. Functional diagram showing basic flow of audio and control in the RT-8 system.



all-transistor, solid-state circuitry, the translator, instead of feeding a teleprinter, can be made to operate a paper strip recorder, a letter-by-letter visual display, or even a "moving billboard" type of dynamic display.

Ah me, what will these machines think of next.

EVER WONDER HOW an NAB exhibit, such as ours, gets put together? Or hadn't it occurred to you that installing the equivalent of a large TV studio in just four days (from move-in to operate) is quite a job. Especially when (a) it must operate pluperfect, and (b) it must have a pleasing, showlike appearance. Take six TV tape recorders, six live studio cameras, three film islands, a complete switching system (with pre-set switching and machine control), a miscellany of audio and accessory equipment, three transmitters, antenna models, etc. Try to get it all in 5000 square feet, leave room for customers, and make it look nice. Yeah, just try—and, remember, four days to do it!

It takes a bit of Planning!!*!?! After twenty years of it we could write a book—and still probably leave some things out. But the picture opposite will give you some idea of how we go about it.

It begins with thinking—and, with us, thinking about NAB is a year-round occupation. But actual brass-tacks planning starts around September 1 (i.e., eight months before Show). At that time we huddle with our merchandise people and the engineers to decide what equipment we will show. By October 1, when the NAB queries us as to space requirements, we have a pretty good idea of what space we will need. The first week of November the NAB has an exhibitors meeting and gives out floor space assignments. We tack this floor layout on our work room wall and start planning in earnest. (First illustration, opposite.)

First we visit the site (polite for "case the joint"), take photographs, make careful measurements. From these we build an exact 1/2-inch scale model of our part of the exhibit hall—including walls, doors, posts and any other obstructions. In this we place 1/2-inch scale models of our equipments—arranging and rearranging till we get a workable layout. This takes quite a time because sales, engineering and "show" factors must be considered.

By January 1, if we are lucky, we have a set layout for equipment. Then we call in our display people and start making sketches for entrances, backgrounds, and overall decorative treatment. Appearance as one enters the exhibit area is important. That's why the eye—looking through the doors of the hall into our exhibit. Signs—something you, as a visitor, are not con-

sciously aware of—are a major headache. Like, where to put them, how big to make them, what to say on them. There must be at least one for each of some fifty major units. And then there has to be sales literature for every unit—with many units so new there isn't a finished model to photograph until just a few weeks (or even days!) before show time. That's why the schedule board you see in one picture opposite. It's a real count-down.

Meanwhile—back in the lab the engineers are having their own scramble. Because there wouldn't be time to wire everything at the convention they have to do it beforehand. Using our floor layout they set everything up in the lab, wire it with necessary cable lengths for the ultimate setup at the show, get it working. Then they dismantle it, carefully keeping all of their pre-cut cables, and load the whole works on the vans ready to go.

When we hit the show site, everything comes in the door in pre-planned order. First day is for laying carpet, setting up backgrounds and supporting structures, marking off spaces for equipment. Second day comes equipment—first big units, then smaller ones—all color-coded as to area they go into. Third day come the engineers. By Saturday morning we're ready to "preview" the setup for our sales people. Comes Sunday morning—and the thundering herd. If we hadn't been through it before, we wouldn't have the nerve to try it. But it started small—many years ago—and has gradually grown (especially in complexity). Every year we say it can't grow any more—but it does!

SILLY SEASON on satellite suggestions sees no surcease. Comes now one alleged expert who says direct satellite-to-home TV is feasible now. He says you don't need 10 KW in the satellite transmitter—as other experts have calculated. All that's necessary is to "pump up" the sensitivity of the home receivers (sic)—by adding to each receiver a 2000 mc converter and a 10-foot parabolic antenna. Simple, isn't it? Of course, that converter would have to be something better than that used in our present microwave systems, and probably would need a parametric amplifier. But then, maybe in quantities of 50 million they would be cheaper. And think of the city skyline with a ten-foot dish on every house. Well, anyway, it would make the dish makers happy.

Almost in the same category is the announcement that "transoceanic stereophonic broadcasting via satellite may not be far off." Well, I'll run home and tell that to my wife! What all these experts lose sight of is the fact that someone will have to pay for these technical tours de force. The fifty million people who vote for Bonanza or Beverly Hillbillies or Peyton Place are not likely to.

Continued on page 46

As We Were Saying

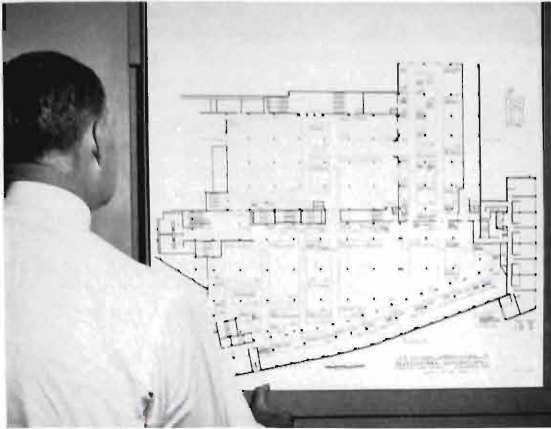

FLOOR PLAN of the Exhibit Hall showing space assigned us by the NAB is our starting point.



PHOTOGRAPHS of our assigned space (mounted on wall) are next step in our exhibit planning.



SKETCHES of construction and exterior facade determine general appearance and theme of the exhibit.



MODEL made to exact scale is used with equipment models to determine best arrangement of equipment.

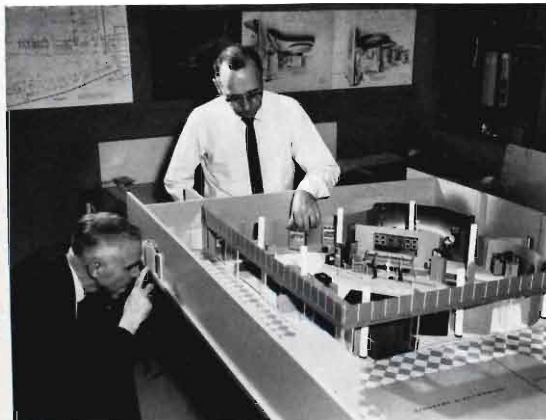

APPEARANCE of the exhibit as one enters is important—hence this eyeing through doorway to Exhibit Hall.



SCHEDULING of everything connected with the exhibit (equipment, displays, literature, etc.) is done on this countdown board.

HERMAN TAYLOR wasn't at the Broadcast Pioneers dinner on February 8, when WTIC received the 1965 Mike Award as "one of America's distinguished pioneer stations." Nor was he at WTIC's fortieth anniversary party on February 10. It would have been nice if he could have been there, for he would have been the only one there who was with WTIC the day it went on the air—February 10, 1925. But inexplicable fate ruled otherwise. For Herman Taylor died January 15, at St. Francis Hospital in Hartford after a short illness.



HERMAN TAYLOR, former chief engineer WTIC, Travelers Insurance Company, Hartford, Connecticut.

Mr. Taylor had been chief engineer of WTIC (AM, FM, TV) for the past 22 years—and assistant chief engineer for 17 years before that. He was not one of the industry's widely known men. But he was well known to many of us at RCA and to station engineers in New England and the East. We knew him as the quiet and persevering man who planned and ran the technical operations of one of the nation's outstanding stations. Our contacts with him dated from 1929 when he installed at WTIC the first production model of the soon-to-become famous RCA 50-B (50-KW) Transmitter. Fifty grand was a lot of power in those days—and the transmitter was first-of-a-kind (sic). It was a time to try men's patience—and to get

well acquainted. It did and we did. It was an acquaintance that carried through WTIC-FM in 1940, WTIC-TV in 1954 and to the present.

Mr. Taylor's own record in radio went much farther back. Like most of the early pioneers he became interested in radio as a boy. He got his first ticket (in 1917) at the age of seventeen. When the Navy wouldn't take him because of his age, he signed on with Marconi as a ship's operator. He remained with Marconi, and subsequently RCA, until 1923. Coming ashore he served for a year as operator and announcer at W DAR—a radio station in Philadelphia. On October 1, 1924, he joined the Traveler's Insurance Company to help plan their upcoming station. He was to remain with WTIC the rest of his life, and to establish a facility of which he was very proud—and justly so.

STRANGE COINCIDENCES sometimes turn up when we start to "research" our notes for this column. One of the papers lent to us by Mr. Taylor's family is a copy of the rotogravure section of the Philadelphia PUBLIC LEDGER for August 17, 1924. It contains a picture (right) of Mr. Taylor handling a remote from the middle of the then unfinished Benjamin Franklin Bridge (the first bridge between Philadelphia and Camden). And just below is another picture in which our Camden Plant (and the building from which we write) is plainly in view. Of course it was the Victor Talking Machine Company when the picture was taken. But radio was already having its effect—and in 1930 it became RCA Victor.

STRANGER STILL is a coincidence which the cynics will hardly believe. Several months ago we decided that this issue should carry a definitive story on the new TK-27 Color Film Camera. It was finished (except for editing) before January. And so—on Page 20 of this issue—you will find an article authored by one of the bright young men in our camera design group. He is Dave Taylor, son of Herman Taylor. We think the old man would be proud.

—The Armchair Engineer



WTIC, 1925. Shown here is the first transmitter installed at WTIC. Mr. Taylor is at the right. The Western Electric 500-watt transmitter will be recognized by many old-timers since it was the transmitter used by a large number of the broadcast stations on the air in the mid-twenties.

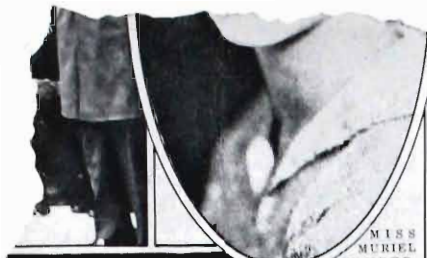

MISS MURIEL VANDERBILT.

daughter of William H. Vanderbilt, 24, who, with her sister, Consuelo, recently had the thrilling experience of being lost for four hours in an open boat off Newport.



A CROSSING OF THE DELAWARE SUCH AS WASHINGTON NEVER IMAGINED. Members of the Joint Bridge Commission, less those who lacked out, starting on the first official inspection of the graceful curves of planks that now binds the two States.



A PUGILISTIC HUCKLEBERRY FINN. Mickey Walker, champion of the welterweights, takes a little time off for fishing while in training at Summit, N. J.

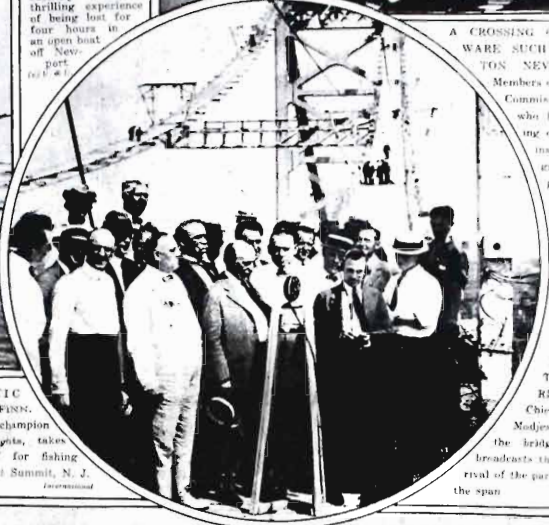

RADIO CARRIES WORD FROM OFFICIAL EXPLODING PARTY ON THE DELAWARE RIVER BRIDGE. Chief Engineer Ralph Modjeski, surrounded by the bridge commissioners, broadcasts the news of the arrival of the party in the center of the span.

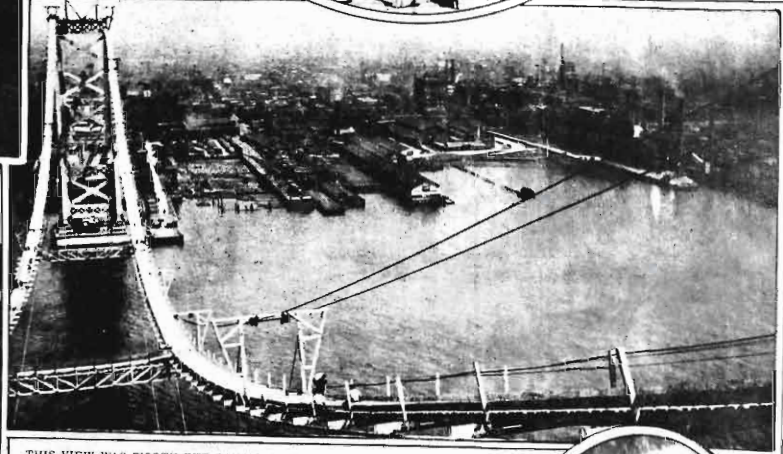

THIS VIEW WAS WORTH THE CLIMB. A glimpse of the panorama the members of the Joint Bridge Commission saw in their jaunt to Camden over the swaying footpaths.

BENJAMIN FRANKLIN BRIDGE, 1924: The above section of the Philadelphia PUBLIC LEDGER for August 17, 1924, shows Herman Taylor handling a remote from the center of the partially finished bridge between Philadelphia and Camden. At the time Mr. Taylor was announcer and engineer for WDAR in Philadelphia. He can be seen at the right of the microphone in the center picture. In the lower picture of the bridge the present plant of RCA can be seen at the upper right.

RCA SERVICE KEEPS ALL YOUR AM, FM, TV EQUIPMENT IN TOP CONDITION



TR-22

TAKE ADVANTAGE OF THE FOLLOWING SERVICES OFFERED BY RCA:

- Video Tape Recorder Service
- TV Camera Overhaul
- TV Transmitter Overhaul
- Installation Supervision
- Microphone and Pick-Up Repairs
- Transmitter Performance Measurements
- Antenna Inspection Measurements
- Console Repairs
- Microwave Service
- TV Projector Service
- Custom Fabrication
- Teletypewriter Maintenance

Your audience demands a superior signal which requires top performance from all your station equipment. RCA Broadcast Service is planned to assure you of meeting this objective. More than 30 years in the broadcast industry have provided a background of solid service experience. This is the type of protection broadcasters have relied on for years, the kind of protection you can count on . . . contract or per-call . . .

from the experts in the service business, RCA Service Company. To guard performance of all your equipment . . . simply telephone one of the following field offices: Atlanta (phone 355-6110), Chicago (WE 9-6117), Phila. (HO 7-3300), Hollywood (OL 4-0880). Or contact Technical Products Service, RCA Service Company, A Division of Radio Corporation of America, Bldg. 203-1, Camden, N.J. 08101.



The Most Trusted Name in Electronics



FM Transmitters



**A whole new line of the finest in FM transmitters
5-kw ... 10-kw ... 20-kw ... designed for Stereo**

RCA gives you the FM Transmitter you want . . . with everything that is new and exciting . . . new-improved stability, simplified operation, space-age styling, full-fidelity sound. Designed for the exacting requirements of FM stereo. Provides excellent performance in monaural and multiplex as well. Ready for remote control and automatic logging.

IMPROVED STABILITY. New circuitry means a new kind of stereo and multiplex performance, with stability never before possible.

SIMPLER OPERATION. New simplified exciter eases operation and maintenance, resulting in greater dependability.

NEW STYLING. Convenient new height, with eye-level metering and space-age colors, combines operating convenience with modern decor.

POWER EXPANSION. All three transmitters are housed in identical enclosures. Field modification of a 5-kw or 10-kw to higher power requires changes only in the basic power-determining parts.

FULL FIDELITY DIRECT FM. The famous RCA direct FM principle, first used in FM transmitters built in 1941, is your assurance of full-fidelity sound.

These are the exciting new transmitters to put your station ahead in FM. Be the first in your market to own one! RCA Broadcast and Television Equipment, Bldg. 15-5, Camden, N.J.



THE MOST TRUSTED NAME IN RADIO



30 kw UHF transmitter

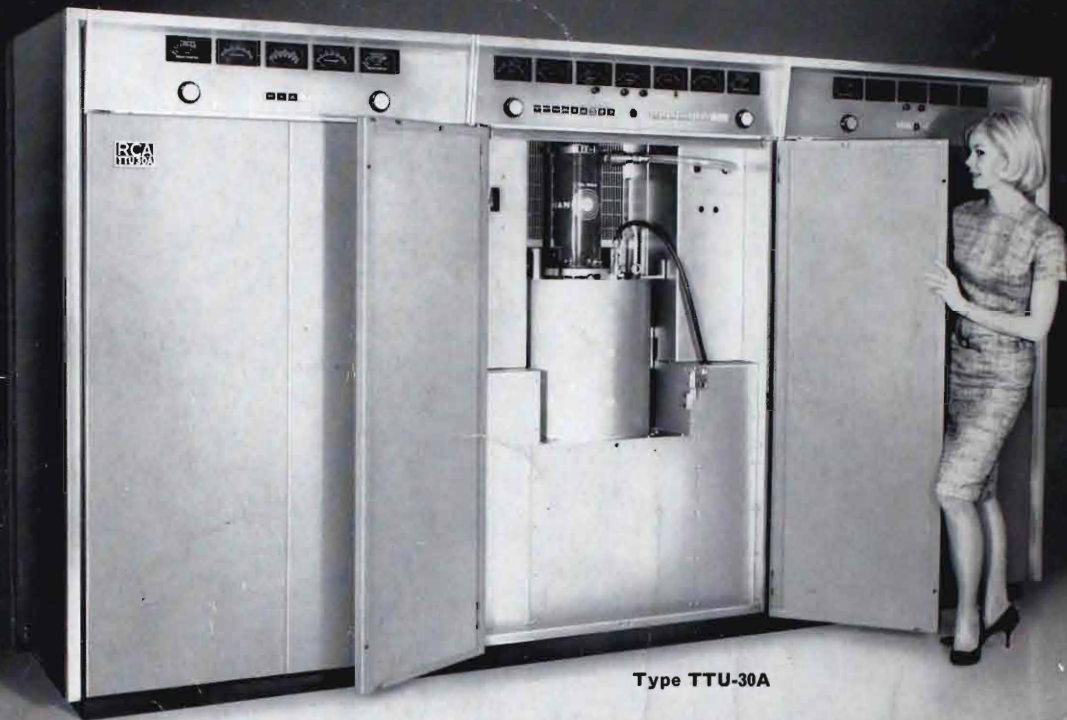

Type TTU-30A

... with long-life, integral-cavity klystrons
has lowest operating cost of any 30-kw UHF transmitter

Here's a brand-new 30-kw transmitter in a compact size, combining top performance with lowest operating cost. It features eye-level, easy-to-read meters, new space-age electronics, new vapor-cooled klystrons. (Vapor cooling uses smaller, more economical heat transfer equipment—reducing operating costs.) . . . Designed for remote control . . . Direct FM aural modulation for finest sound . . . to 1,000,000 watts ERP . . . Also in this new line are a completely air-cooled 10-kw, and a 2-kw that easily can be expanded to a 10-kw.



Klystron change is accomplished in only a few minutes with this unique carriage.

RCA Broadcast and Television Equipment,
Building 15-5, Camden, N.J.



THE MOST TRUSTED NAME IN TELEVISION